



UnderCover

INSTALLATION

CONTENTS

TABLE DES MATIÈRES | INHALT

Introduction	2
Safety Symbols	3
System Components	4
System Specifications	5
Checklist	6
Mounting Distance	11
Pivot Mounts	12
Stub Mount (Optional)	14
Pivot Mount (continued)	16
Lower Arm	18
Lower Arm Cylinder	19
Upper Arm	20
Crossbar Cylinders	21
Rollerbar	22
Crossbar Inserts	23
Crossbar	24
Headboard Legs	25
Headboard Leg (Option 1)	26
Valve Mount Bracket	27
Headboard Leg (Option 2)	28
Headboard Mounting	29
Pump Mounting	30
Pump Mount (Optional)	31
Tarp	35
Rollerbar Tensioning	38
Buffer Arm	40
Pump Electrical Circuit	42
Hydraulic Diagram	43
Operation	44
Maintenance	50
Daily / Monthly Checks	51

INTRODUCTION

INTRODUCTION | EINFÜHRUNG



Thank you for purchasing a Transcover ground level covering system. It has been designed and manufactured by Transcover to provide years of trouble-free operation.

Please read and understand this Installation Manual before installing your system. Correct installation is a requirement for correct operation. Please pay particular attention to the stability of the installation and to the safety indication symbols in the document.



Nous vous remercions d'avoir acheté un système de couverture de niveau de Transcover. Il a été conçu et fabriqué par Transcover pour fournir des années de fonctionnement sans problème.

Veillez lire et comprendre ce manuel d'installation avant d'installer votre système. Une installation correcte est une exigence pour un fonctionnement correct. Veuillez noter une attention particulière à la stabilité de l'installation et aux symboles d'indication de sécurité dans le document.



Vielen Dank für den Kauf eines Transcover Bodenniveau Abdecksystem. Es wurde von Transcover entworfen und hergestellt, um jahrelang einen störungsfreien Betrieb zu bieten.

Bitte lesen und verstehen Sie diese Installationsanleitung, bevor Sie Ihr Abdecksystem installieren. Die korrekte Installation ist eine Voraussetzung für einen korrekten Betrieb. Bitte beachten Sie die Stabilität der Anlage und die Sicherheitshinweise im Dokument.

**CONTACT TRANSCOVER FOR FURTHER INSTRUCTIONS BEFORE
CARRYING OUT ANY WORK THAT IS NOT DESCRIBED IN THIS DOCUMENT.**

**CONTACTEZ-NOUS POUR OBTENIR D'AUTRES INSTRUCTIONS
AVANTEFFECTUER TOUT TRAVAIL QUI N'EST PAS DÉCRIT DANS CE
DOCUMENT.**

**FÜR WEITERE ANWEISUNGEN VORDIE AUSFÜHRUNG VON ARBEITEN, DIE
IN DIESEM DOKUMENT NICHT BESCHRIEBEN SIND.**

Warranty terms available at www.transcover.com/warranty

SAFETY SYMBOLS

SYMBOLES DE SÉCURITÉ | SICHERHEITSSYMBOL



- Wear Head Protection
- Port du casque de sécurité obligatoire
- Kopfschutz tragen



- Do NOT operate in high winds
- Ne pas faire fonctionner en cas de vents violents
- Nicht bei starkem Wind bedienen



- Tarp Out
- Replier la bâche
- Plane einfahren



- Wear High Visibility Clothing
- Porter des vêtements à haute visibilité
- Warnkleidung tragen



- Do NOT climb
- Ne pas monter
- Nicht klettern



- Tarp In
- Replier la bâche
- Plane einfahren



- Wear safety goggles
- Porter des lunettes de sécurité
- Schutzbrille tragen



- Caution
- Attention
- Achtung



- Weld
- Soudure
- Schweißen



- Wear Protective Gloves
- Porter des gants de protection
- Schutzhandschuhe tragen



- Refer to operators manual
- Se reporter au manuel d'utilisation
- Siehe Bedienungshandbuch



- Cut
- Couper
- Schneiden



- Crush hazard, keep hand clear of moving parts
- Danger d'écrasement. Rester à l'écart des pièces en mouvement
- Quetschgefahr. Halten Sie sich von beweglichen Teilen fern



- Inspect equipment before use
- Inspecter la corde et la bâche avant utilisation
- Überprüfen Sie vor dem Gebrauch Seil und Plane



- Drill
- Percer
- Bohren



- Keep hands free of moving parts
- Risque de pincement. Rester à l'écart des pièces en mouvement
- Einklemmgefahr. Halten Sie sich von beweglichen Teilen fern

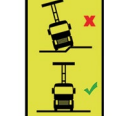

- Ensure ground is level before use
- Veiller à ce que le terrain soit plat avant utilisation
- Stellen Sie vor Gebrauch sicher, dass der Boden eben ist



- Measure
- Mesure
- Messen



- Trip hazard
- Risque de trébuchement
- Stolpergefahr



- Up
- Haut
- Aufwärts



- Check Level
- Vérifier le niveau
- Kontrollstufe



- Falling object hazard
- Se méfier des chutes d'objets
- Achten Sie auf fallende Gegenstände



- Down
- Vers le bas
- Unten



- Check square
- Vérifier la place
- Check für Platz



- Beware of overhead power cables
- Se méfier des câbles aériens
- Achten Sie auf Oberleitungen



- Up
- Haut
- Aufwärts



- Wear a welding mask
- Porter un masque de soudure
- Tragen Sie eine Schweißmaske



- Electrical hazard
- Risque électrique
- Stromschlaggefahr

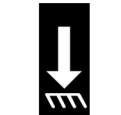

- Down
- Vers le bas
- Unten



- Use lifting equipment
- Utiliser un équipement de levage
- Verwenden Sie Hebezeuge



- Switch On
- allumer
- anstellen



- Caution, can cause injury
- Attention, peut causer des dommages
- Vorsicht, kann Schäden verursachen



- Switch Off
- éteindre
- ausschalten

SYSTEM COMPONENTS

COMPOSANTS DU SYSTÈME | SYSTEMTEILE

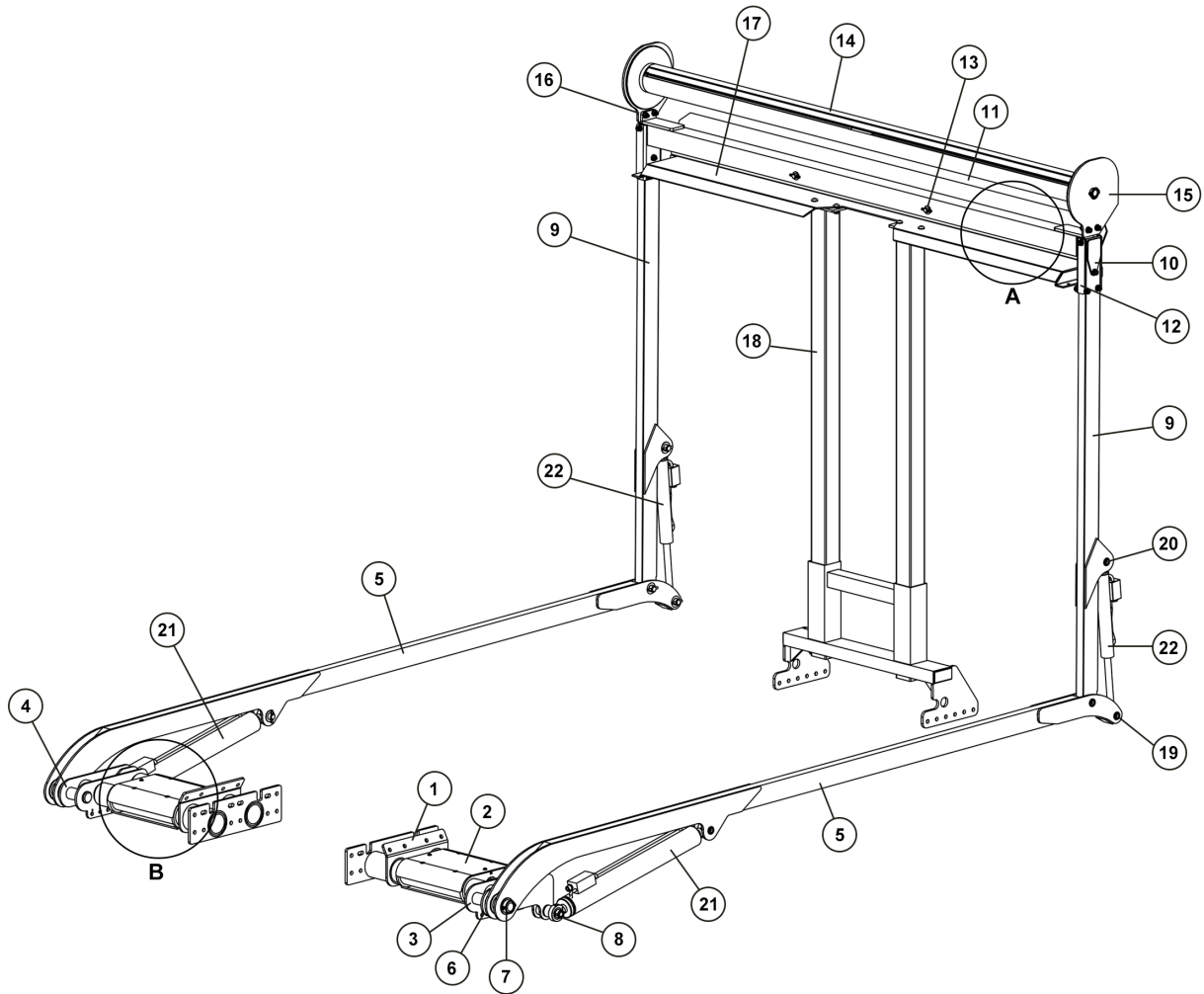

NO	PART DESCRIPTION	PART NO.	QTY
1	Pivot Mount Stub Bracket	UC-XR-01	2
2	Pivot Mount	UC-PM-01	2
3	Pivot Mount Insert - RH	UC-PMI-01	1
4	Pivot Mount Insert - LH	UC-PMI-02	1
5	Lower Arm	UC-LARM-01	2
6	Lower Arm Spacer	UC-PMS-01	2
7	Lower Arm Collar	UC-COL-02	2
8	Cylinder Mount Pin Collar	UC-COL-01	2
9	Upper Arm	UC-UARM-01	2
10	Upper Arm Cover Plate	UC-UACP-01	2
11	Crossbar	UC-CB-01	1
12	Crossbar Insert	UC-CBI-01	2
13	Crossbar Pin	UC-PIN-01	2
14	Rollerbar	U-ROLLER-07	1
15	Ear - RH	UC-HBE-02	1
16	Ear - LH	UC-HBE-01	1
17	Headboard Tray	UC-HB-01	1
18	Headboard Leg	AC-HBLEG-01	2
19	AC 76mm Pin	U-PIN-02	4
20	AC 72mm Pin	U-PIN-03	2
21	Cylinder - Lower Arm	UC-HCYL-01	2
22	Cylinder - Upper Arm	UC-HCYL-02	2
23	Cylinder - Crossbar	UC-HCYL-03	2
24	Cylinder - Pivot	UC-HCYL-04	2

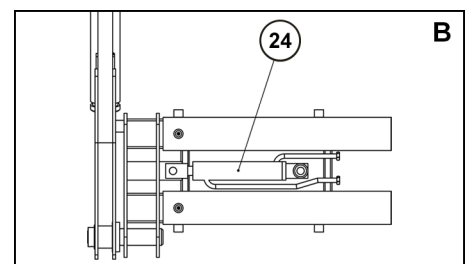
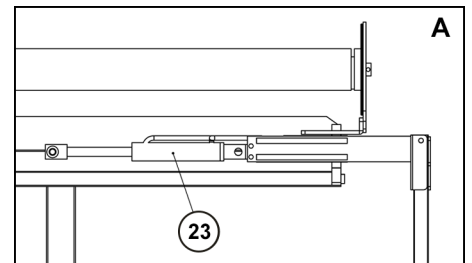

SYSTEM SPECIFICATIONS

SPÉCIFICATIONS DU SYSTÈME | SYSTEMSPEZIFIKATIONEN

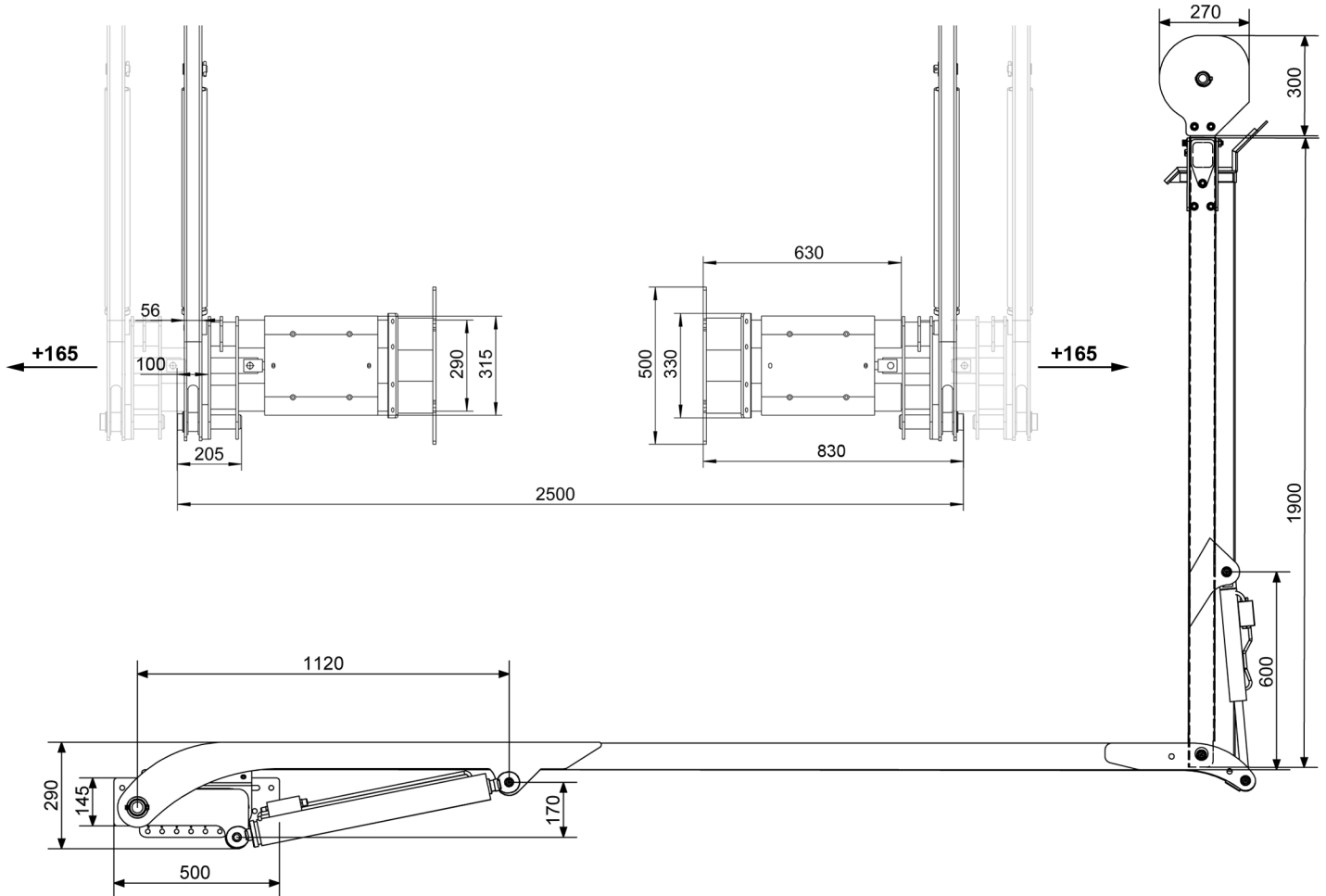

SYSTEM SPECIFICATIONS

Versions available

Hydraulic Wireless Remote
Hydraulic Tri-Lever Control

Body

CHEM and DIN standard versions (up to 7m)
CHEM and DIN standard Containers

Weight

475kg

Tarps

Duramesh
Supermesh
Powermesh
Style Standard / Side-Flaps / X-Span

Warranty

1 year warranty

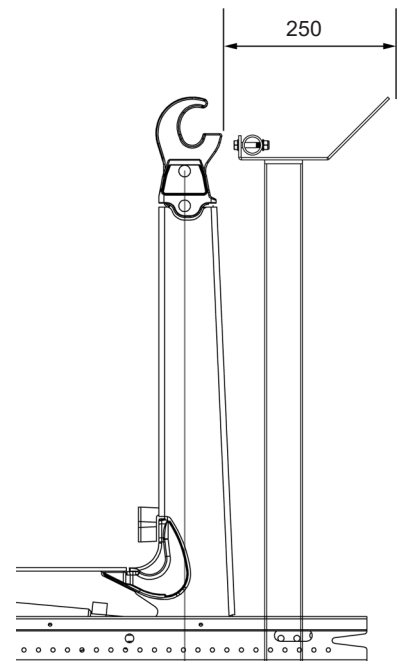





Mounting bracket provided to suit manufacturer

CHECKLIST 1/5

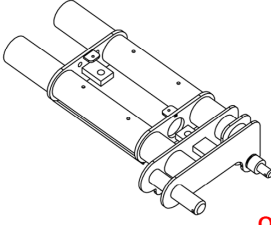
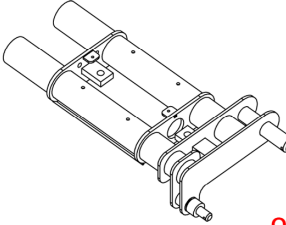
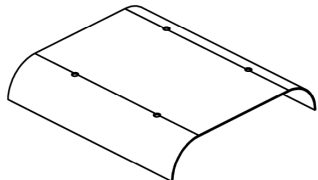
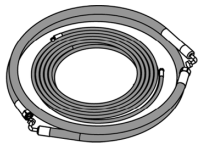
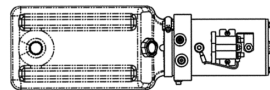
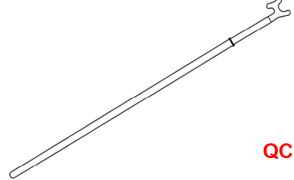
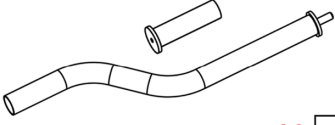
LISTE DE VÉRIFICATION 1/5 | CHECKLISTE 1/5

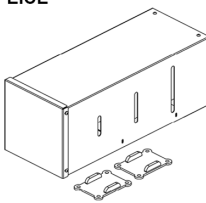
PALLET BOX - LAYER 1

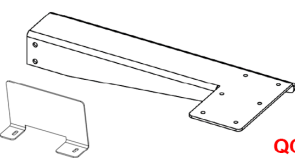
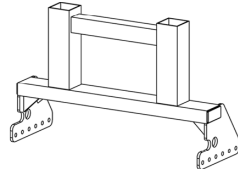
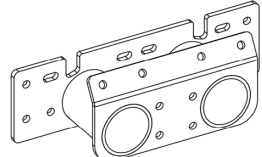
 <p>QC <input type="checkbox"/></p> <p>Pivot Mount + Insert RH CODE: UC-PM-03</p> <p>x 1 <input type="checkbox"/></p>	 <p>QC <input type="checkbox"/></p> <p>Pivot Mount + Insert LH CODE: UC-PM-02</p> <p>x 1 <input type="checkbox"/></p>	 <p>QC <input type="checkbox"/></p> <p>Pivot Mount Cover CODE: UC-PMCP-01</p> <p>x 2 <input type="checkbox"/></p>
 <p>QC <input type="checkbox"/></p> <p>Hose Kit & Fittings CODE: UC-HHK-01 CODE: UC-HHK-02</p> <p>x 1 <input type="checkbox"/></p>	 <p>QC <input type="checkbox"/></p> <p>Hydraulic Pump CODE: U-HPUMP-02</p> <p>x 1 <input type="checkbox"/></p>	 <p>QC <input type="checkbox"/></p> <p>Boat Hook CODE: U-EXTH-01</p> <p>x 1 <input type="checkbox"/></p> <p>5 PEICE</p>
 <p>QC <input type="checkbox"/></p> <p>Buffer Arm CODE: UC-BA-01</p> <p>x 2 <input type="checkbox"/></p>	 <p>QC <input type="checkbox"/></p> <p>Crossbar Insert CODE: UC-CBI-01</p> <p>x 2 <input type="checkbox"/></p>	 <p>QC <input type="checkbox"/></p> <p>Hydraulic Pump Mount + Cover CODE: U-HMPC-01</p> <p>x 1 <input type="checkbox"/></p>
 <p>QC <input type="checkbox"/></p> <p>Headboard Leg Mount CODE: U-HBLMB-01</p> <p>x 2 <input type="checkbox"/></p>	<p>OPTIONAL EXTRA COMPONENTS (SEE WORKS ORDER)</p>	
 <p>QC <input type="checkbox"/></p> <p>Button Mount Plate CODE:</p> <p>x 1 <input type="checkbox"/></p>	 <p>QC <input type="checkbox"/></p> <p>XR Tower Mount CODE: UC-XR-02</p> <p>x 1 <input type="checkbox"/></p>	 <p>QC <input type="checkbox"/></p> <p>Pivot Mount Stub CODE: CHECK WORKS ORDER FOR STYLE</p> <p>x 2 <input type="checkbox"/></p>
<p>Valve Mount CODE: U-HPLVM-01</p> <p>x 1 <input type="checkbox"/></p>		

QC VISUAL INSPECTION

Paint & Finish

Free from marks, scratches, blemishes, chips and cracking



Packing & Wrapping

Packaging in good condition. Contents safe from Water. Boxes are strong sealed and secure.

CHECKLIST 2/5

LISTE DE VÉRIFICATION 2/5 | CHECKLISTE 2/5

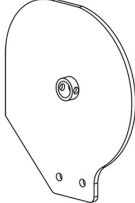

PALLET BOX - LAYER 1 - CONTINUED

	QC <input type="checkbox"/>		QC <input type="checkbox"/>		QC <input type="checkbox"/>
Straps	x 2 <input type="checkbox"/>	Headboard Ear LH	x 1 <input type="checkbox"/>	Headboard Ear RH	x 1 <input type="checkbox"/>
AC Tarp CODE: AC-TARP-01		CODE: UC-HBE-01		CODE: UC-HBE-02	

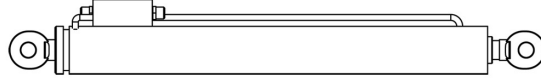
PALLET BOX - LAYER 1 - CYLINDER CARTON A

	QC <input type="checkbox"/>
UC Cylinder Lower Arm	x 2 <input type="checkbox"/>
CODE: UC-HYCL-01	

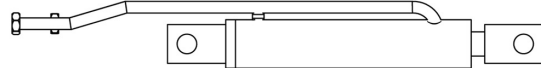
PALLET BOX - LAYER 1 - CYLINDER CARTON B

	QC <input type="checkbox"/>		QC <input type="checkbox"/>
UC Cylinder Crossbar	x 2 <input type="checkbox"/>	UC Pivot Mount Cylinder	x 2 <input type="checkbox"/>
CODE: UC-HCYL-03		CODE: UC-HYCL-04	

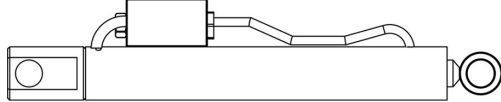
	QC <input type="checkbox"/>
UC Cylinder Upper Arm	x 2 <input type="checkbox"/>
CODE: UC-HCYI-02	

QC VISUAL INSPECTION

Paint & Finish

Free from marks, scratches, blemishes, chips and cracking

Packing & Wrapping

Packaging in good condition. Contents safe from Water. Boxes are strong sealed and secure.

CHECKLIST 3/5

LISTE DE VÉRIFICATION 3/5 | CHECKLISTE 3/5

PALLET BOX - LAYER 1 - BOX - LAYER 1

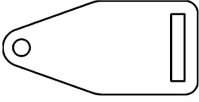
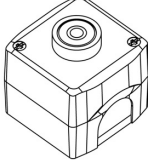
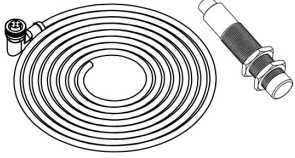
					
Upper Arm Cover Plate CODE: UC-UACP-01	x 2 <input type="checkbox"/>	Pump Button CODE: U-PSW-01	x 1 <input type="checkbox"/>	ELD Prox Sensor + Cable CODE: U-PSC-01	x 1 <input type="checkbox"/>

OPTIONAL - CHECK WORKS ORDER

BOX - LAYER 1 (SEE PAGE 4 FOR BREAKDOWN)

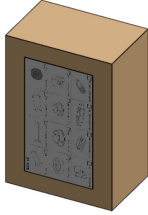
			
Bolt Kit CODE: UC-BOLT-01	x 1 <input type="checkbox"/>	Hardware Kit CODE: N/A	x 1 <input type="checkbox"/>

BOX - LAYER 2

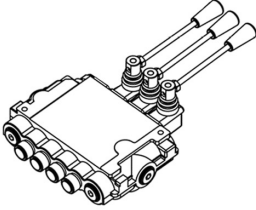
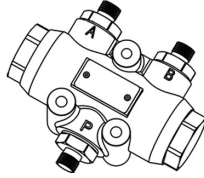
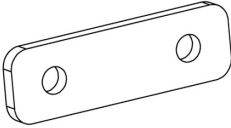
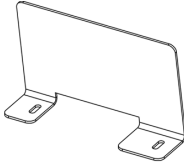
Part No: 200061132339		3 x MTD A08006M OR 3 x MTD A08008M DO NOT MIX	
MUST BE PAINTED BLACK PLEASE CHECK		MUST BE PAINTED BLACK PLEASE CHECK	
			
3 Handle Control CODE: U-HVC-03	x 1 <input type="checkbox"/>	Flow Divider CODE: U-HVS-01	x 3 <input type="checkbox"/>
			
OPTIONAL - CHECK WORKS ORDER XR Stub Packer Plate CODE:	QC <input type="checkbox"/> x 4 <input type="checkbox"/>	Button Mount Plate CODE:	QC <input type="checkbox"/> x 1 <input type="checkbox"/>

QC VISUAL INSPECTION

Paint & Finish

Free from marks, scratches, blemishes, chips and cracking

Packing & Wrapping





Packaging in good condition. Contents safe from Water. Boxes are strong sealed and secure.

CHECKLIST 4/5

LISTE DE VÉRIFICATION 4/5 | CHECKLISTE 4/5

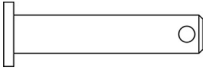
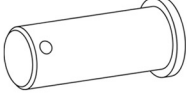
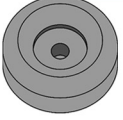
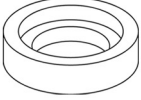
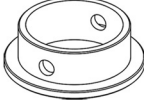
BOX 1A

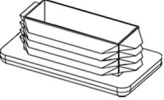
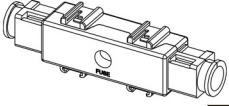
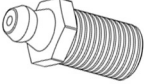
INCLUDING GREASE NIPPLES

 78mm Pin CODE: U-PIN-02 x8 <input type="checkbox"/>	 Crossbar Pin (99mm) CODE: UC-PIN-01 x2 <input type="checkbox"/>	 UC Cylinder Mount Pin CODE: UC-PIN-02 x2 <input type="checkbox"/>	 Round Buffer CODE: U-BUFF-04 x2 <input type="checkbox"/>
 Pivot Mount Spacer CODE: U-PMS-01 x2 <input type="checkbox"/>	 Lower Arm Collar CODE: UC-COL-02 x2 <input type="checkbox"/>	 Cylinder Mount Collar CODE: UC-COL-01 x2 <input type="checkbox"/>	 Valve Mount End Cap CODE: AC-CAP-03 x1 <input type="checkbox"/>
 250A Fuse & Holder CODE: U-250F-01 x1 <input type="checkbox"/>	 Grease Nipple - Large CODE: N/A x8 <input type="checkbox"/>	 Buffer Large (AC) CODE: U-BUFF-05 x2 <input type="checkbox"/>	

BOX 1A - PICKED & CHECKED

BOX 1B

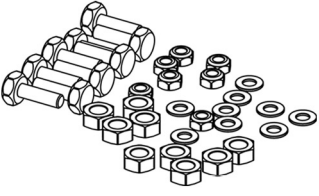

Bolt Kit
CODE: UC-BOLT-01 **x1**

4 M5 x 20 Set	20 M10 Washers
8 M5 Washers	10 M10 Nylock Nuts
4 M5 Nylock Nuts	4 M12 x 40 Set
2 M6 x 60 Bolts	4 M12 x 40 Socket Cup Set
3 M6 x 160 Bolts	6 M12 x 70 Button Head Set
10 M6 Washers	2 M12 x 110 Socket Cup Set
5 M6 Nylock Nuts	28 M12 Washers
6 M8 x 20 Buttonheads	16 M12 Nylock Nuts
2 M8 x 25 Button Head Set	8 M14 x 75 Bolts
6 M8 x 50 Bolt	8 M14 Nylock Nuts
4 M8 x 65 Socket Cup Set	16 M14 Washers
4 M8 x 80 Bolt	2 M16 Nylock
6 M8 x 25 Repair Washers	2 M16 Washer
24 M8 Washers	4 M20 x 70 Bolt
20 M8 Nylock Nuts	8 M20 Washers
4 M10 x 16 Button Head	4 M20 Nylock Nuts
2 M10 x 50 Bolt	8 1" Washers
2 M10 x 35 Button Heads	12 Stainless Roll Pins 8 x 45mm
4 M10 x 30 Set	2 Spring Clips/linch Pins M10
4 M10 x 60 Bolts	2 4mm x 40mm Split Pins

BOX 1B - PICKED & CHECKED

QC VISUAL INSPECTION

Paint & Finish

Free from marks, scratches, blemishes, chips and cracking

Packing & Wrapping

Packaging in good condition. Contents safe from Water. Boxes are strong sealed and secure.

CHECKLIST 5/5

LISTE DE VÉRIFICATION 5/5 | CHECKLISTE 5/5

PALLET BOX - LAYER 2 - USE CUTOUTS TO POSITION COMPONENTS IN PALLET

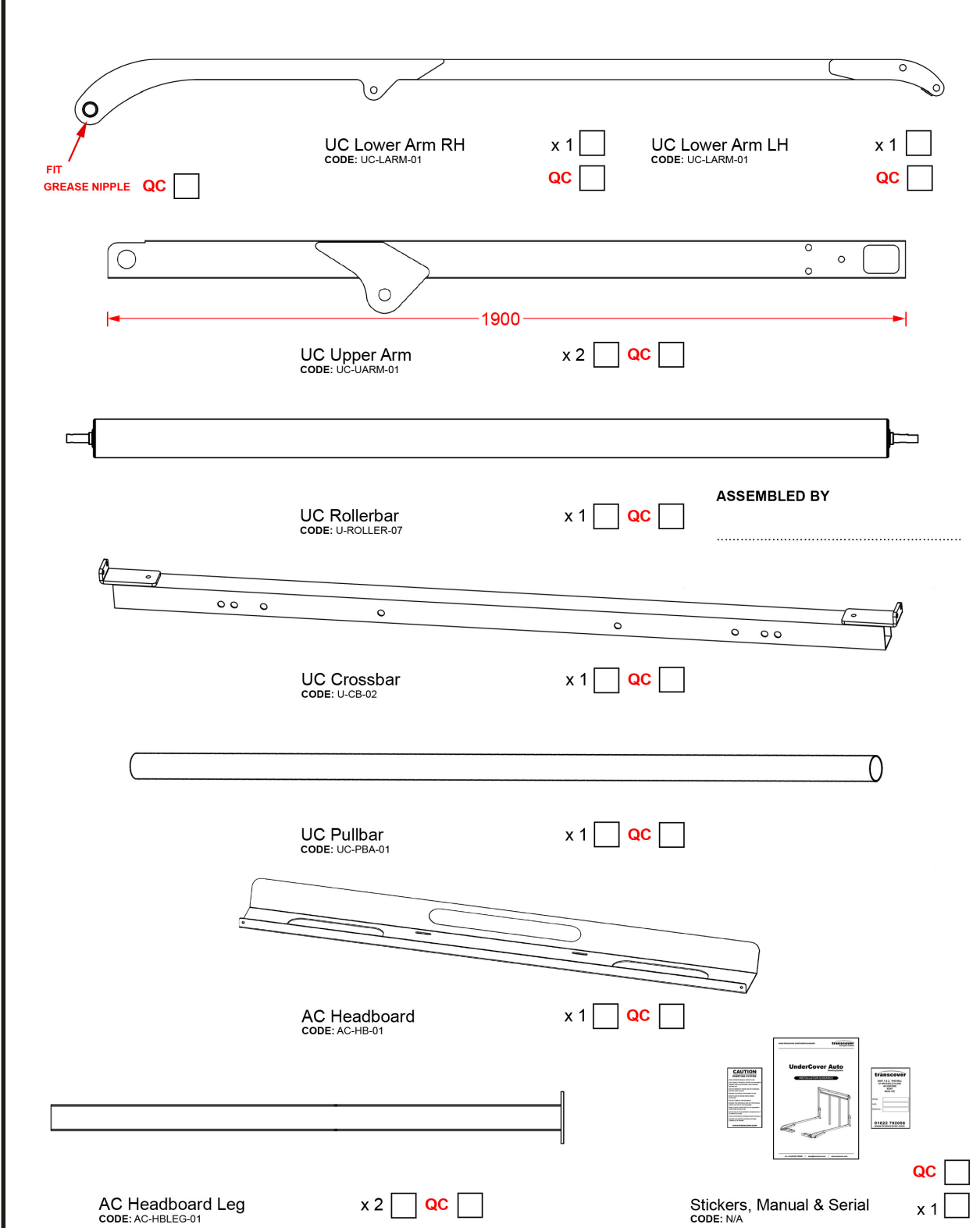

FIT GREASE NIPPLE QC

UC Lower Arm RH CODE: UC-LARM-01 x 1 QC

UC Lower Arm LH CODE: UC-LARM-01 x 1 QC

UC Upper Arm CODE: UC-UARM-01 x 2 QC

UC Rollerbar CODE: U-ROLLER-07 x 1 QC ASSEMBLED BY

UC Crossbar CODE: U-CB-02 x 1 QC

UC Pullbar CODE: UC-PBA-01 x 1 QC

AC Headboard CODE: AC-HB-01 x 1 QC

AC Headboard Leg CODE: AC-HBLEG-01 x 2 QC

Stickers, Manual & Serial CODE: N/A x 1 QC

QC VISUAL INSPECTION

Paint & Finish

Free from marks, scratches, blemishes, chips and cracking

Packing & Wrapping

Packaging in good condition. Contents safe from Water. Boxes are strong sealed and secure.

MOUNTING DISTANCE

DISTANCE DE MONTAGE | MOUNTING DISTANCE

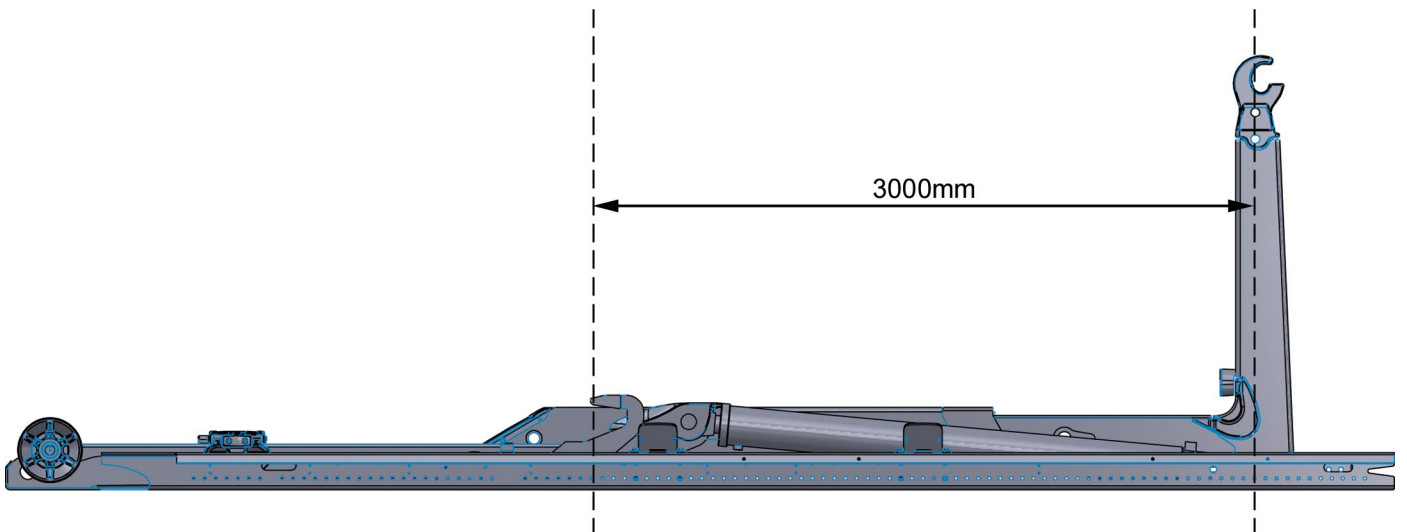
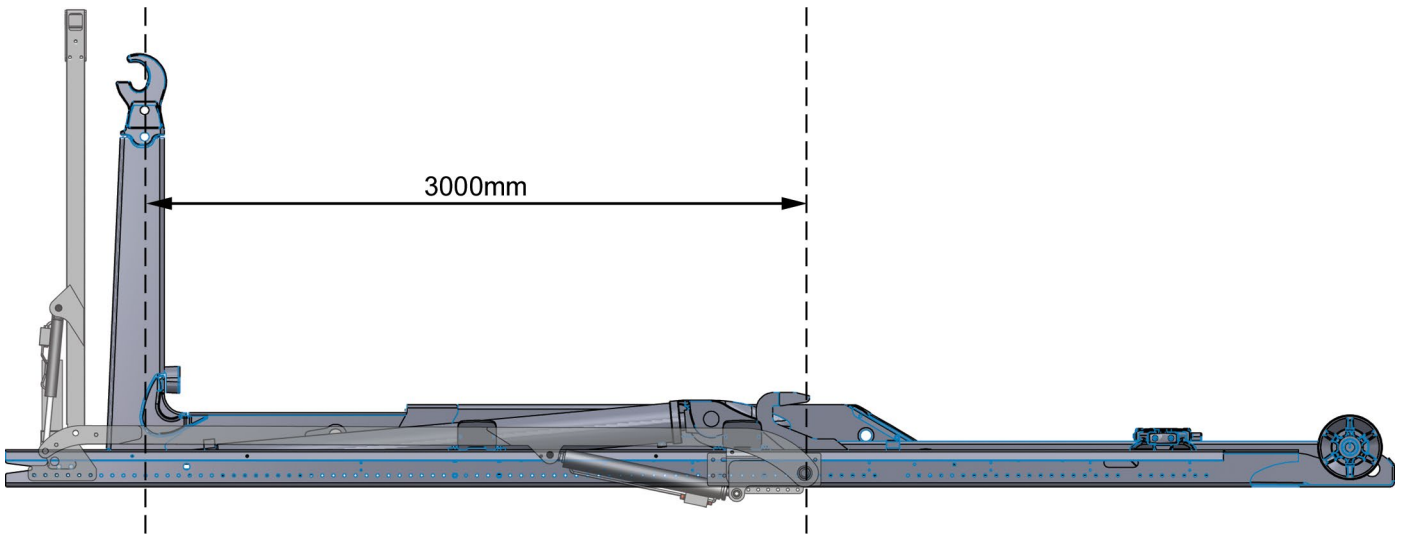

INSTALLING PIVOT MOUNTS

INSTALLATION DE FIXATIONS PIVOTANTES | INSTALLATION DER PIVOTBEFESTIGUNGEN

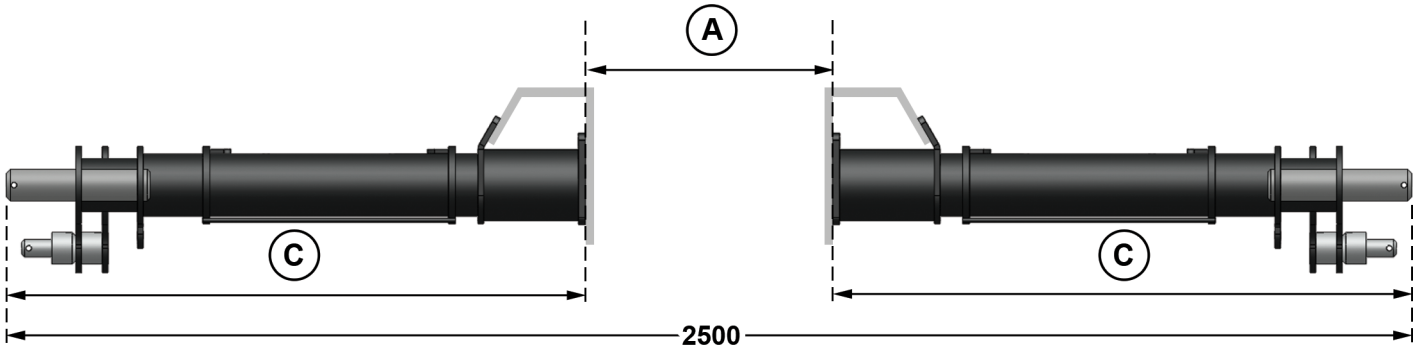

$$2500 - \textcircled{A} = \textcircled{B}$$

$$\textcircled{B} \div 2 = \textcircled{C}$$

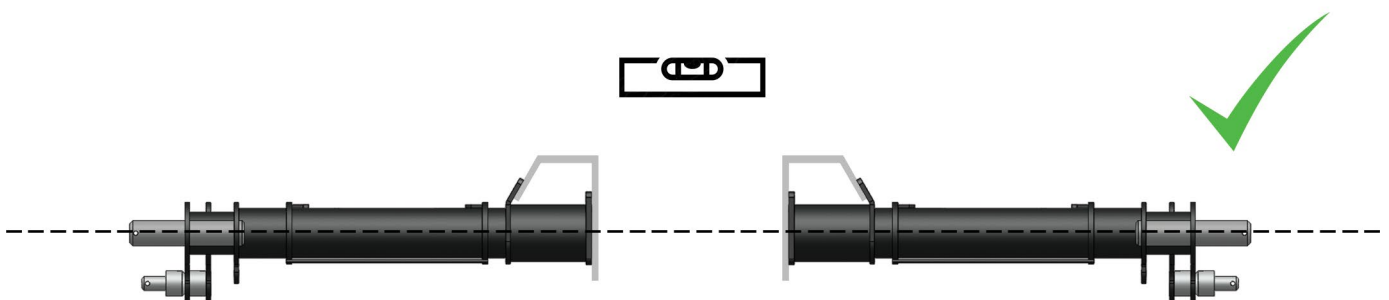
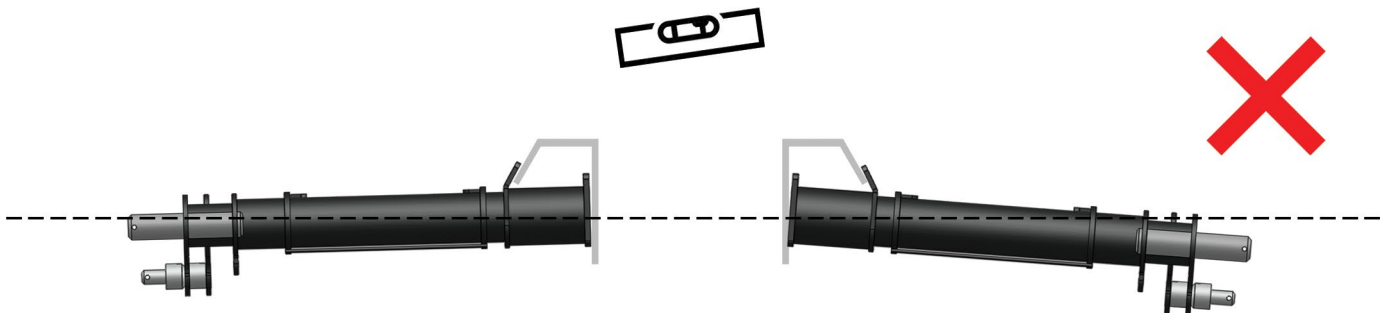

INSTALLING PIVOT MOUNTS

INSTALLATION DE FIXATIONS PIVOTANTES | INSTALLATION DER PIVOTBEFESTIGUNGEN



WELDED OPTION

LH SIDE SHOWN

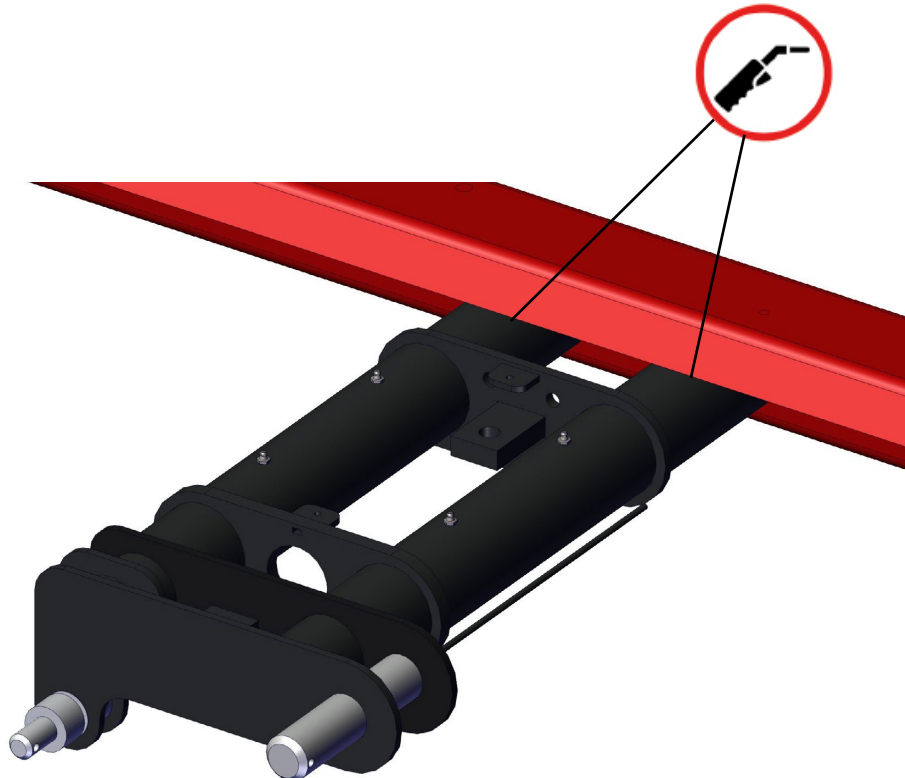
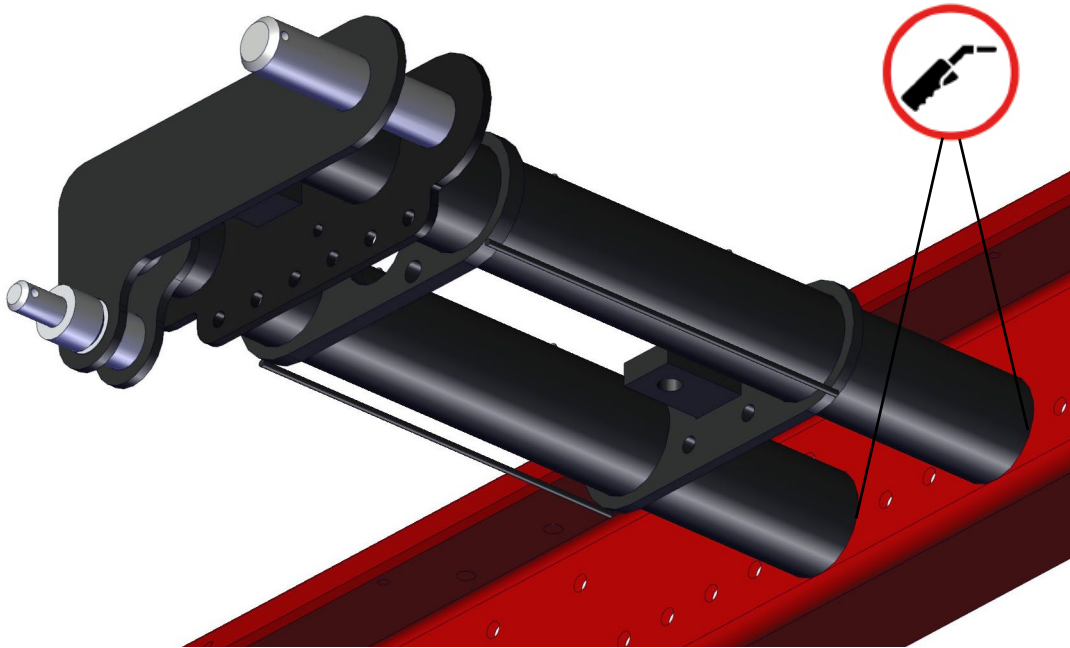

OPTIONAL STUB MOUNTS - OPTION A

ASSEMBLAGE CADRES DE MONTAGE | INSTALLATIONSHALTERUNGEN



- BOLTS NOT SUPPLIED
- BOLTS NICHT GELIEFERT

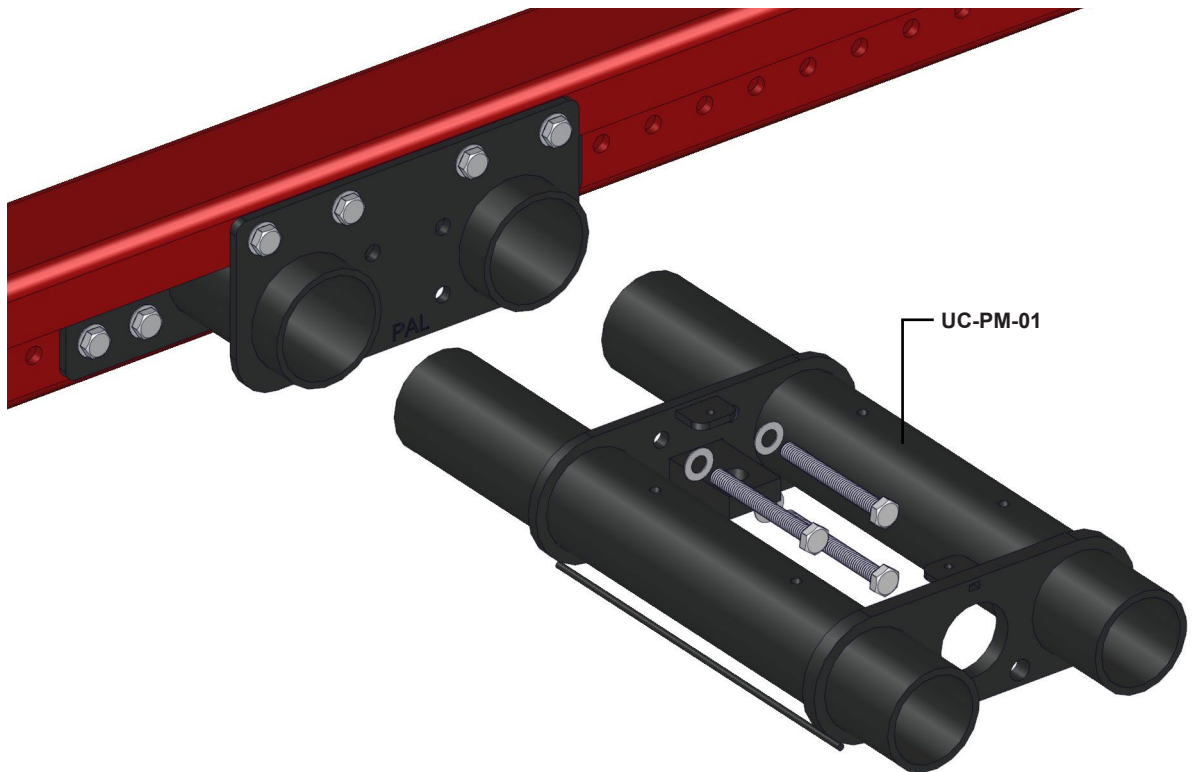
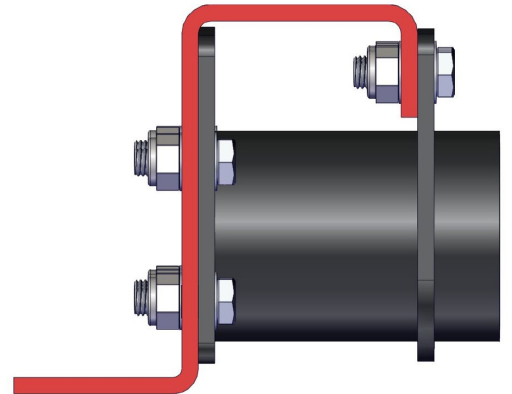

OPTIONAL STUB MOUNTS - OPTION B

ASSEMBLAGE CADRES DE MONTAGE | INSTALLATIONSHALTERUNGEN



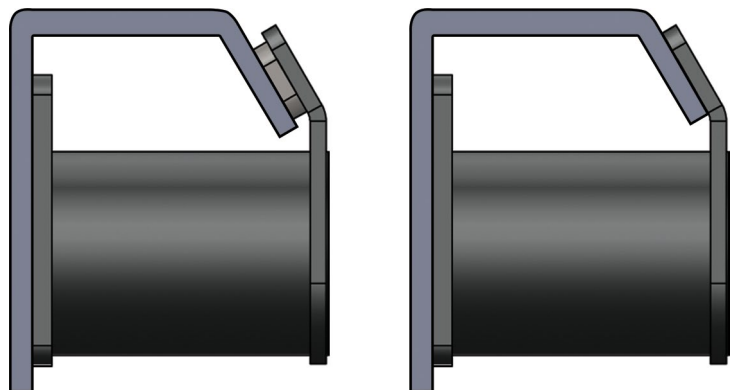
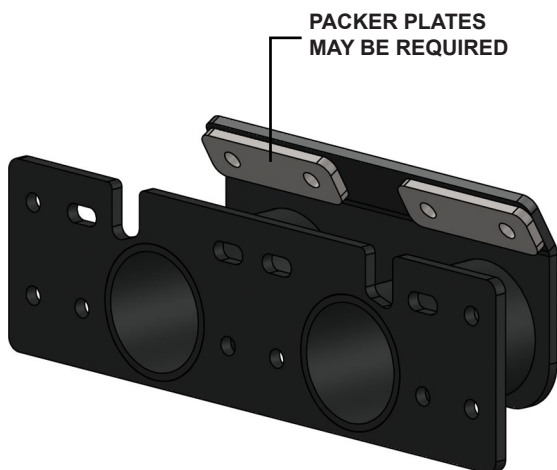
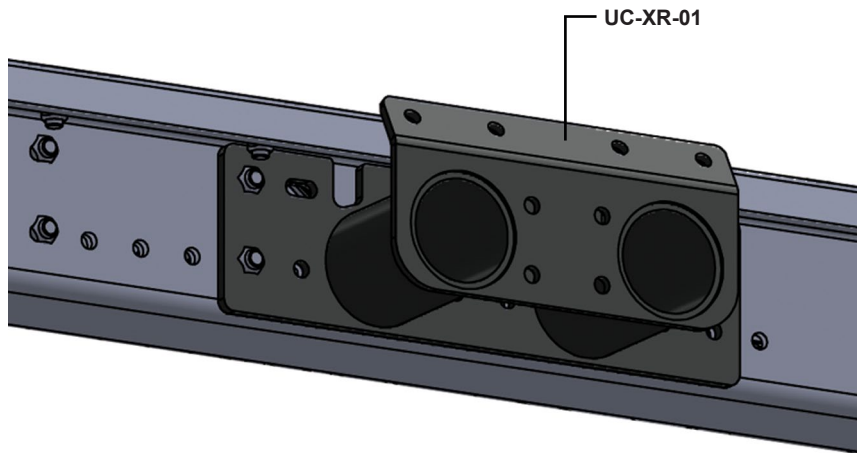
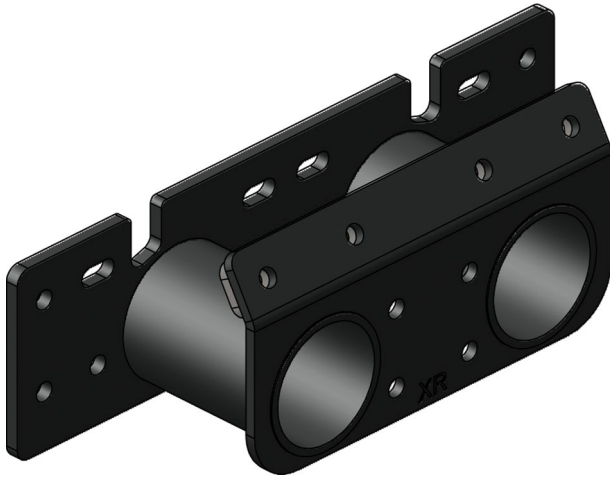

- BOLTS NOT SUPPLIED
- BOLTS NICHT GELIEFERT



OPTIONAL STUB MOUNTS - OPTION B

INSTALLATION DE MONTAGE EN OPTION | OPTIONALE MONTAGEINSTALLATION



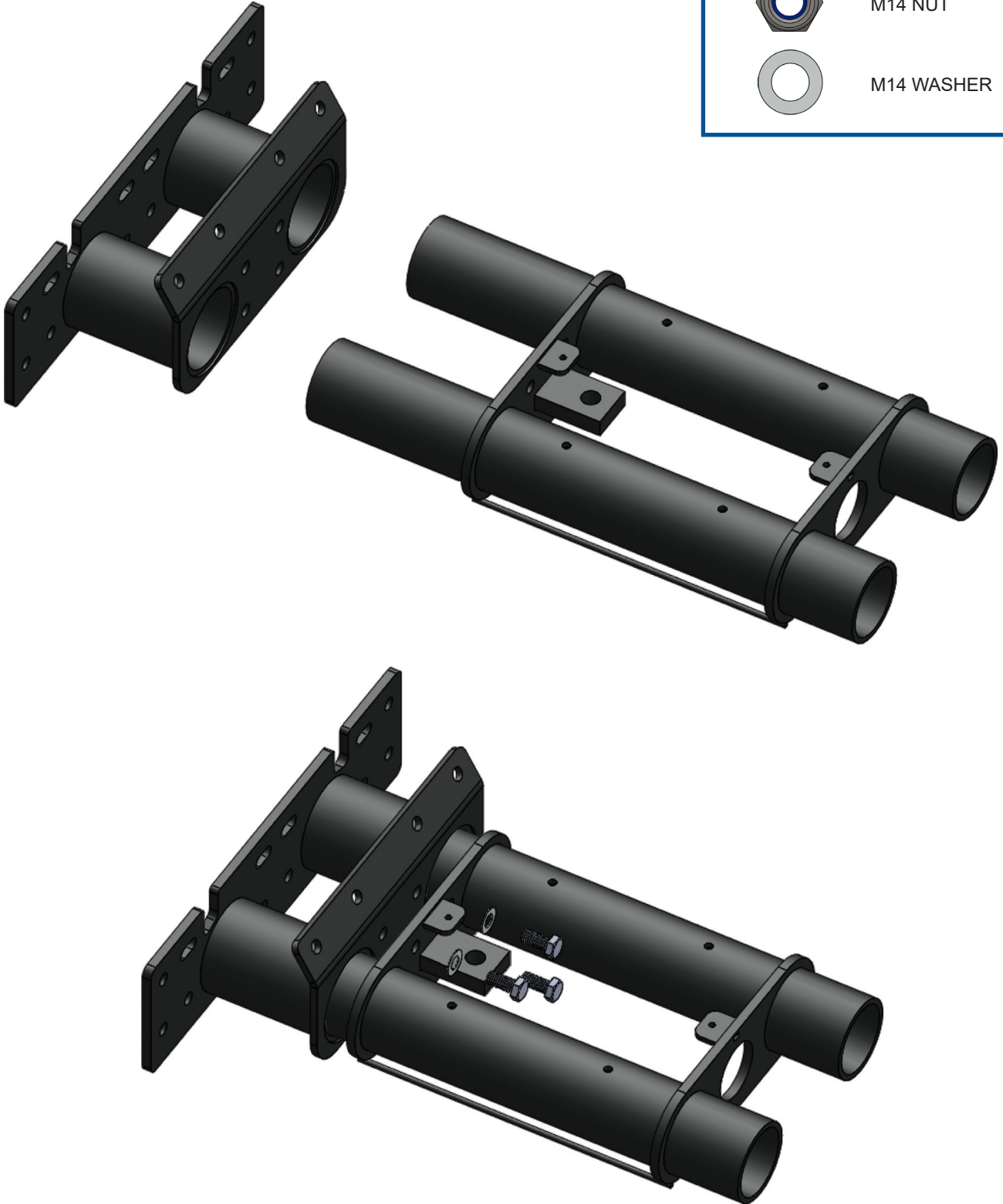

	M14 x 75 BOLT	x 8
	M14 NUT	x 8
	M14 WASHER	x 16



INSTALLING PIVOT MOUNTS

INSTALLATION DE FIXATIONS PIVOTANTES | INSTALLATION DER PIVOTBEFESTIGUNGEN



	M20 x 70 BOLT	x 4
	M20 NUT	x 4
	M20 WASHER	x 8

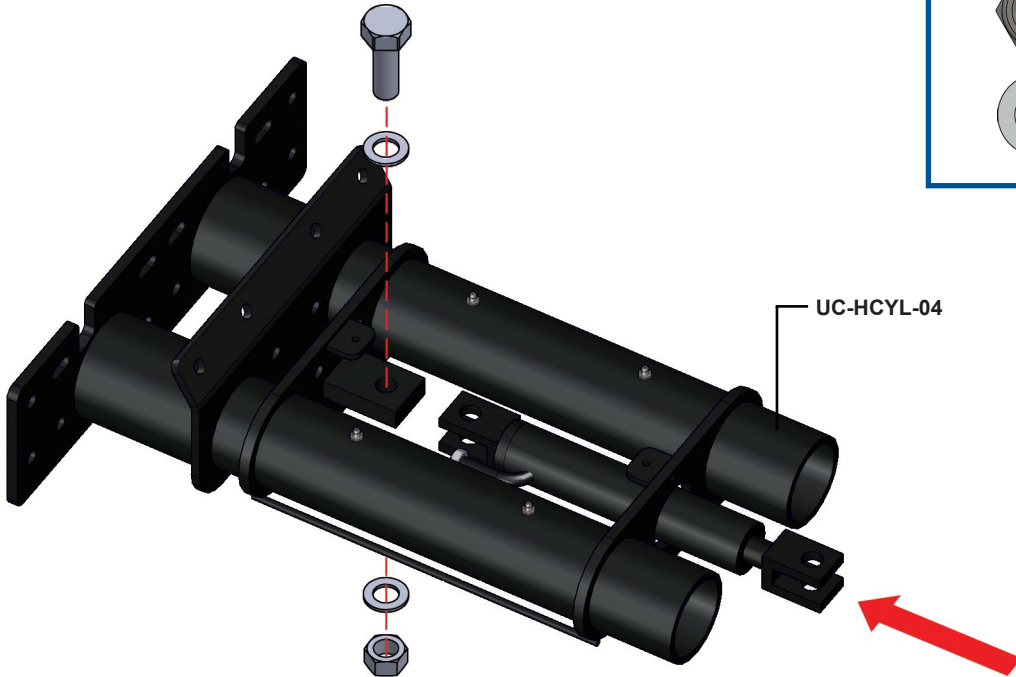

UC-HCYL-04

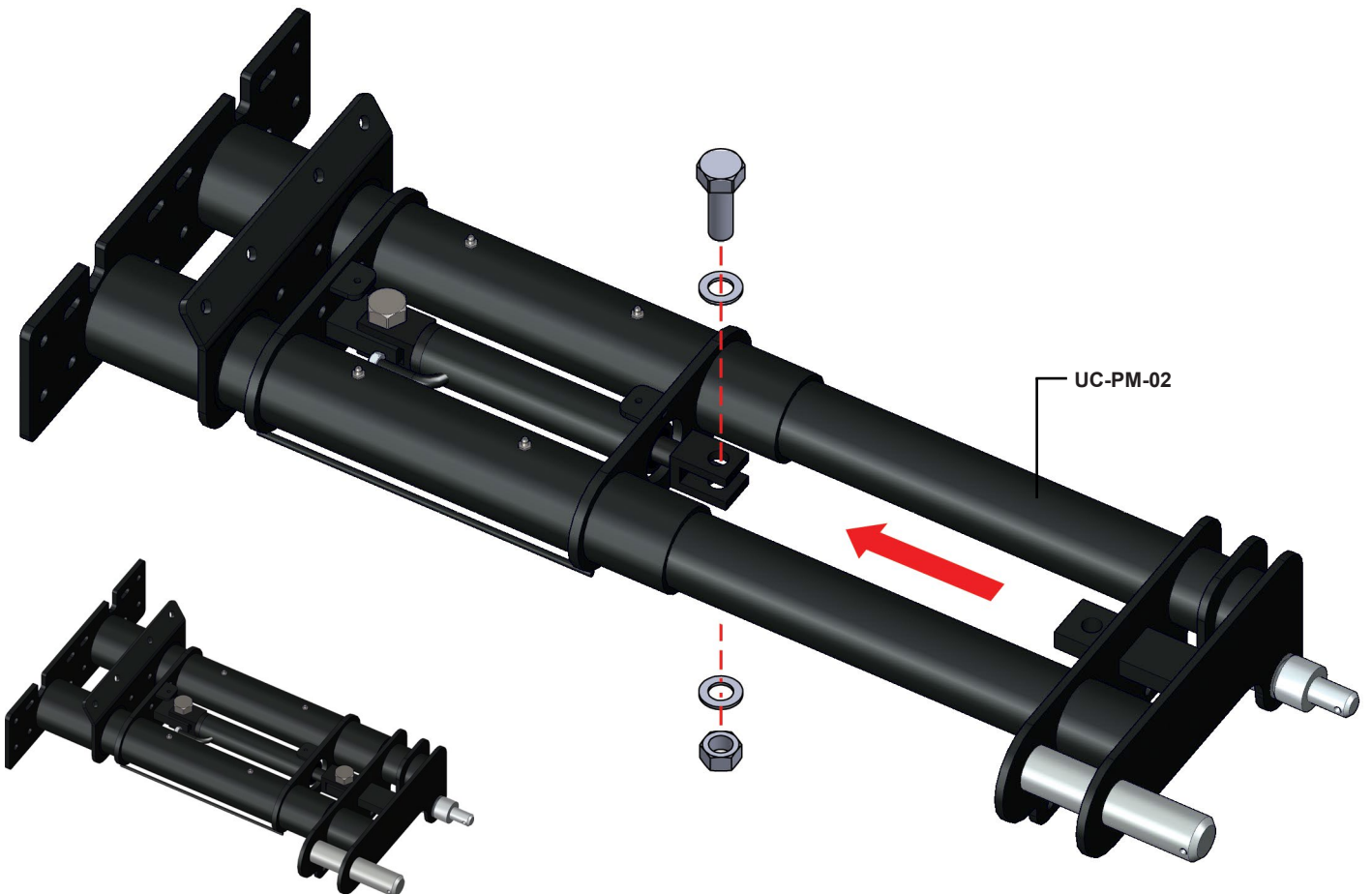

UC-PM-02

INSTALLING PIVOT MOUNTS

INSTALLATION DE FIXATIONS PIVOTANTES | INSTALLATION DER PIVOTBEFESTIGUNGEN

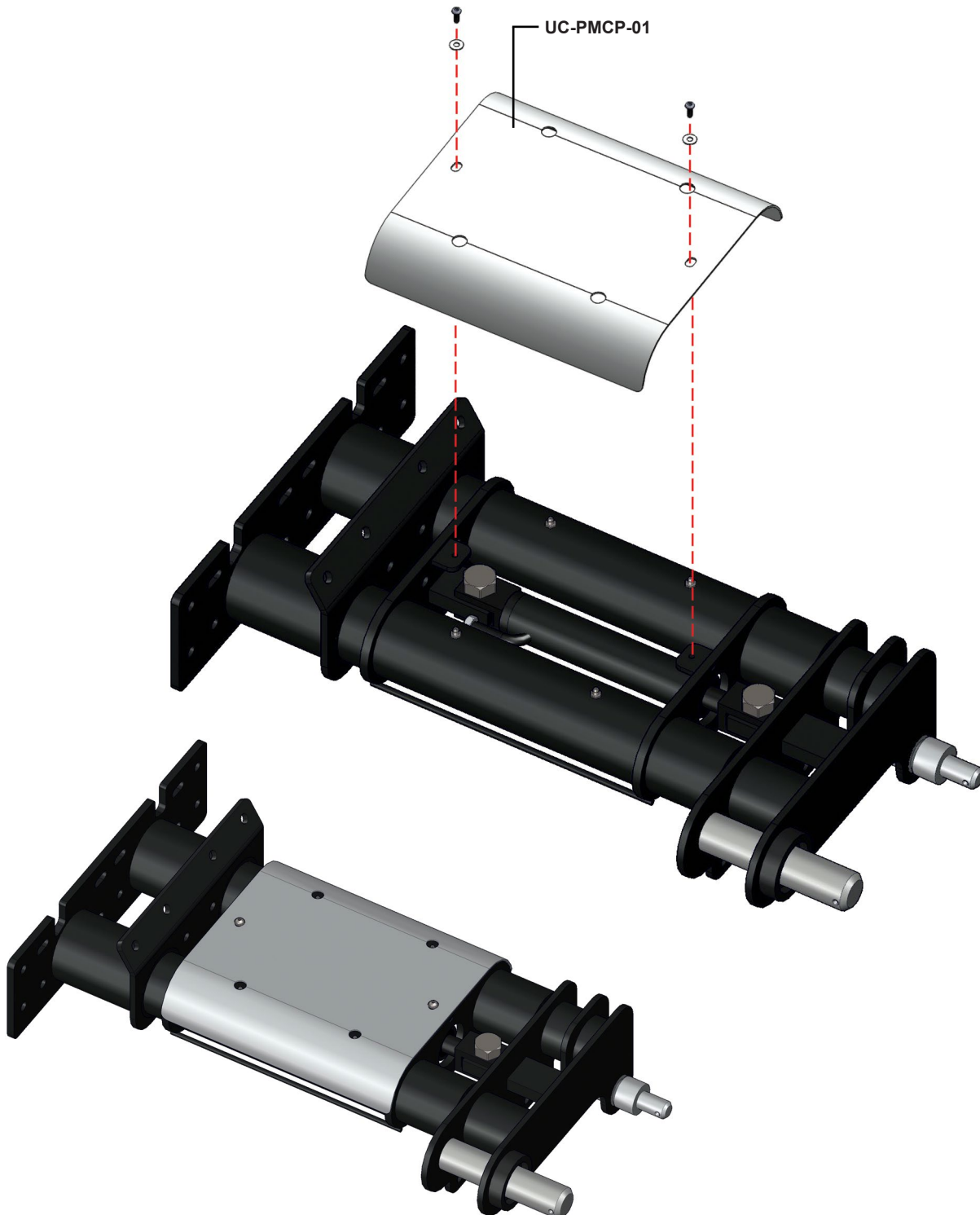
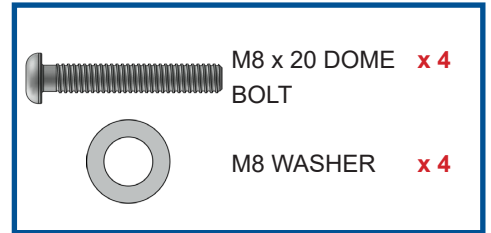

INSTALLING LOWER ARM

INSTALLATION DU BRAS INFÉRIEUR | INSTALLATION DES UNTEREN ARMS

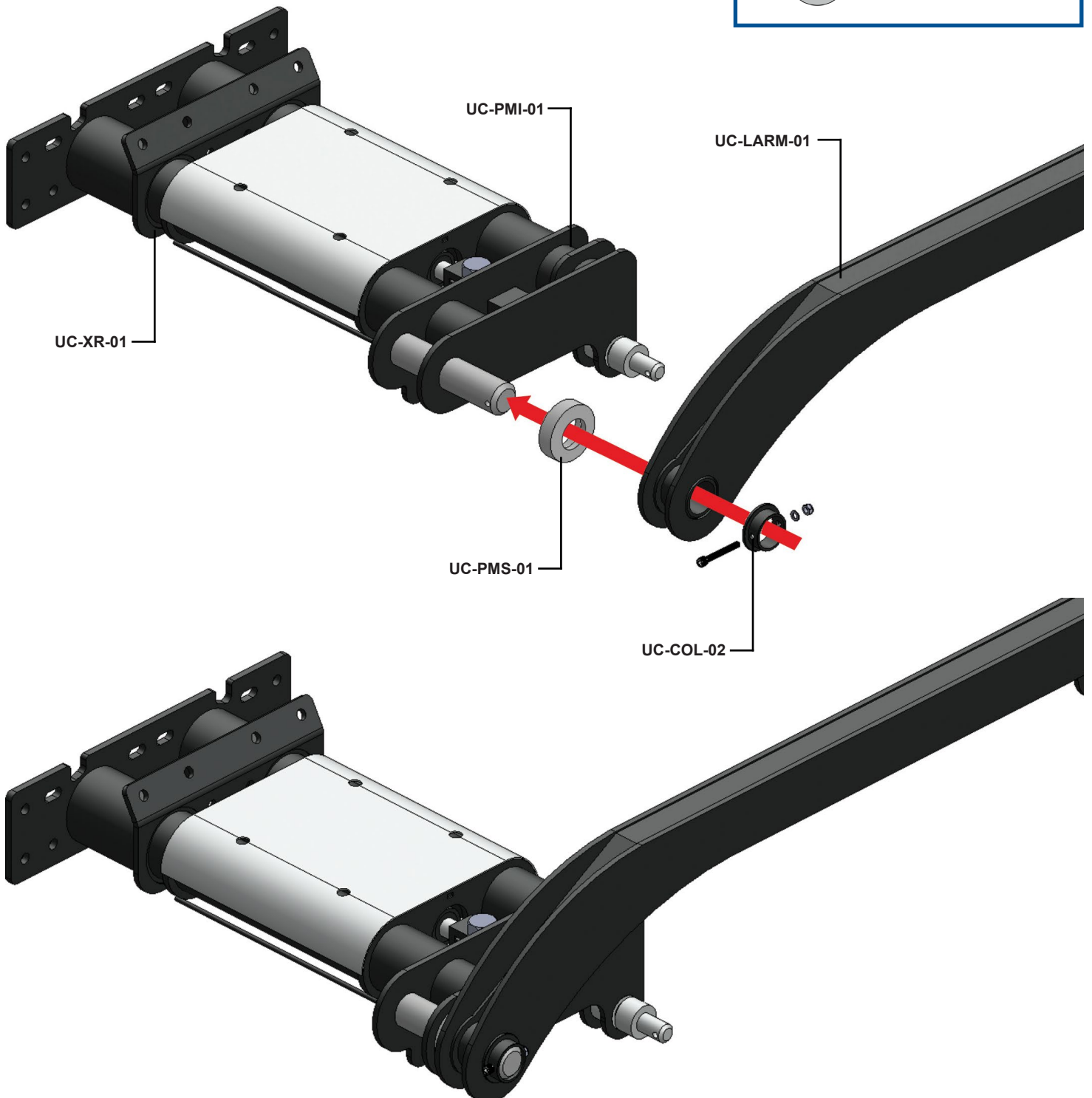
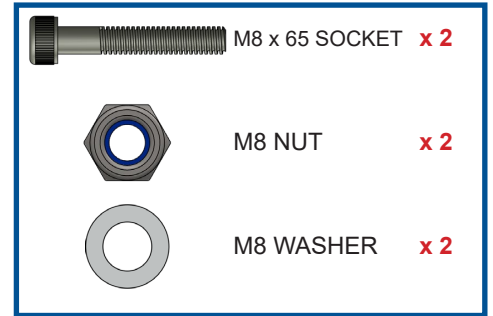

INSTALLING LOWER ARM CYLINDER

INSTALLATION DU CYLINDRE DE BRAS INFERIEUR | INSTALLATION DES UNTEREN ARMZYLINDERS

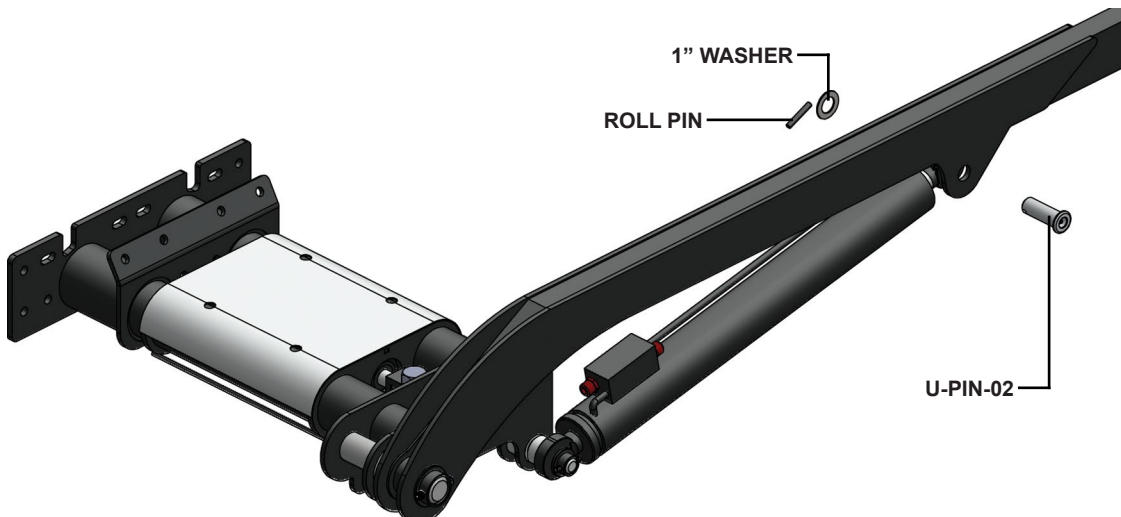
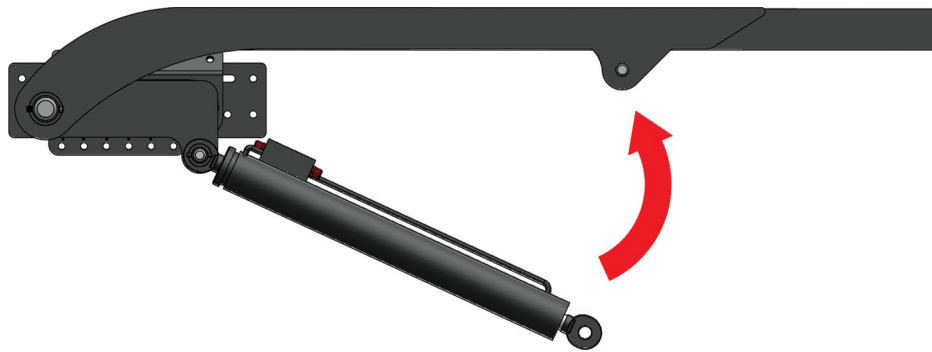
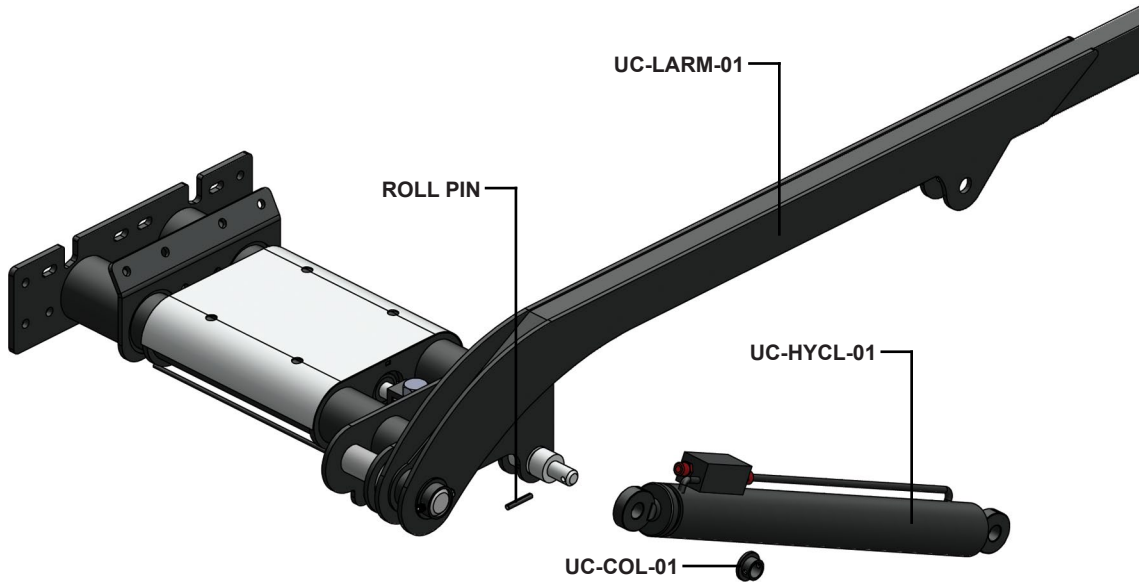

INSTALLING UPPER ARMS & CYLINDERS

INSTALLATION DES BRAS SUPÉRIEURS | INSTALLATION DER OBEREN ARME

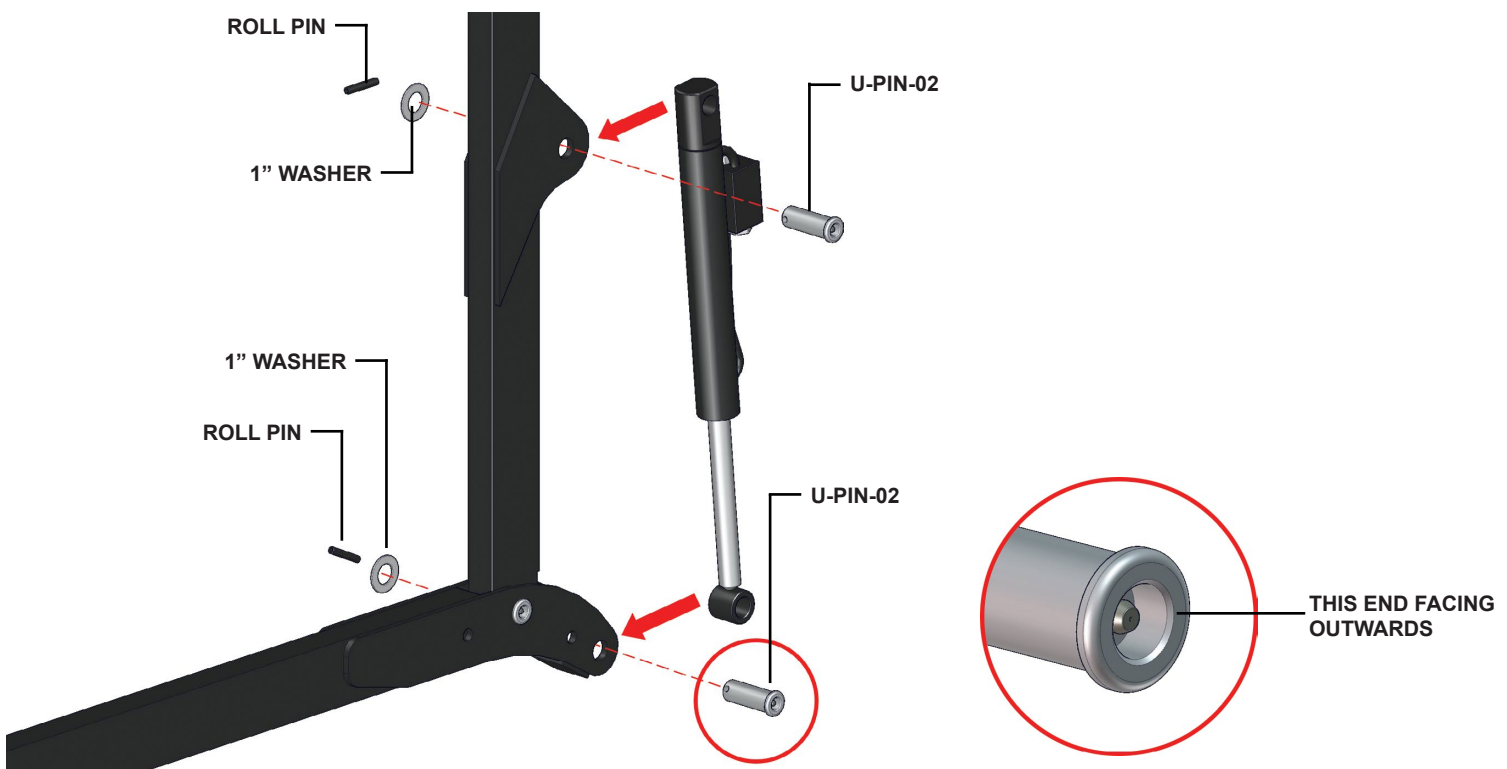
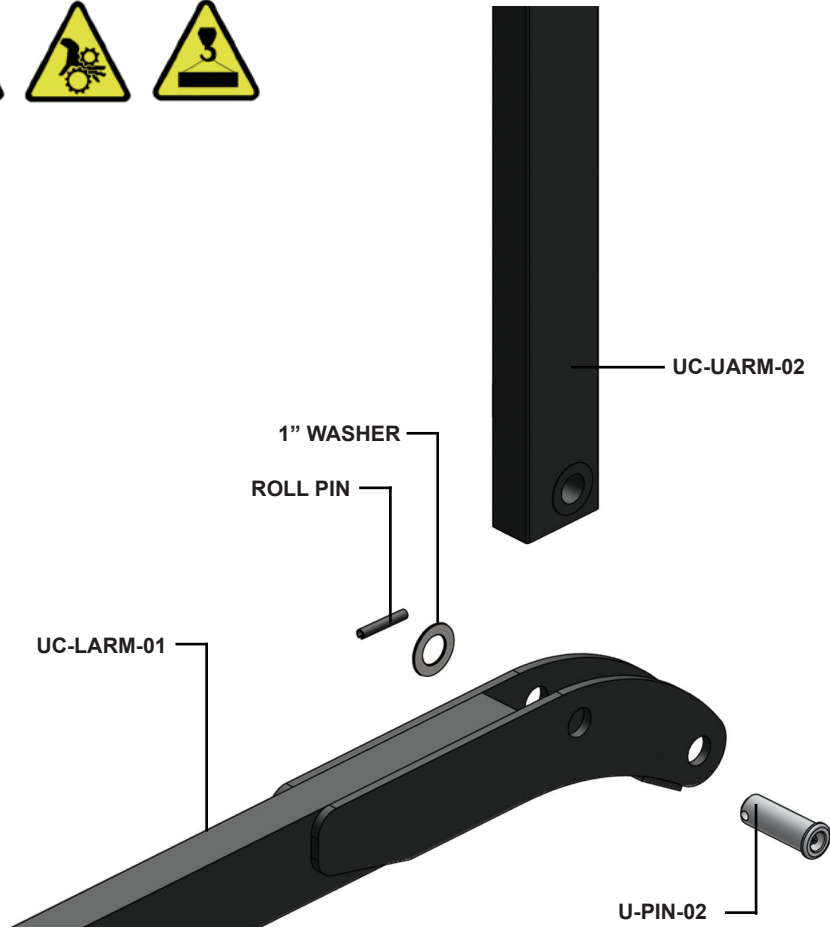

INSTALLING CROSSBAR CYLINDERS

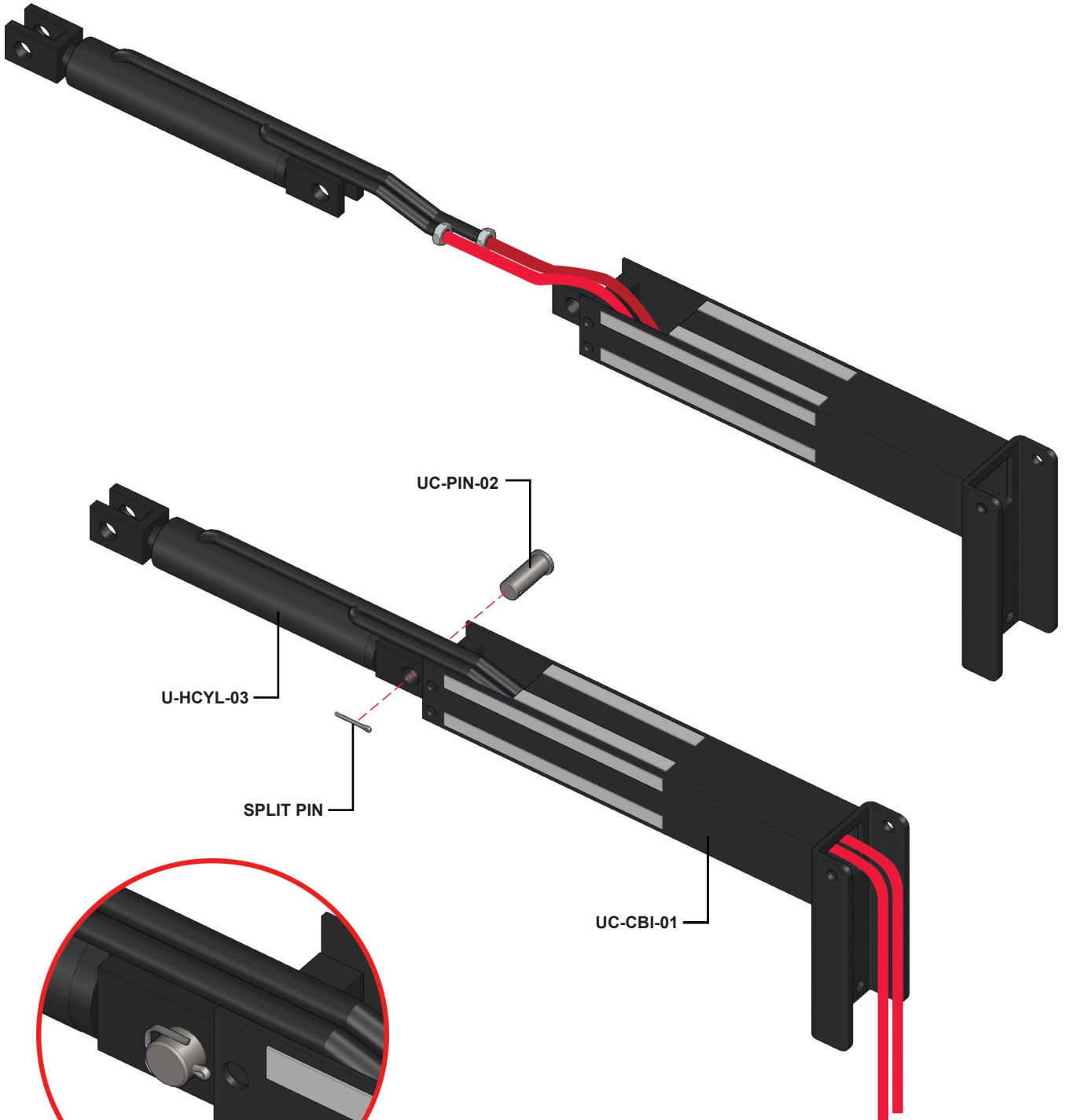

INSTALLATION DU CYLINDRE À BARRE TRANSVERSALE | INSTALLATION VON CROSSBAR CYLINDER

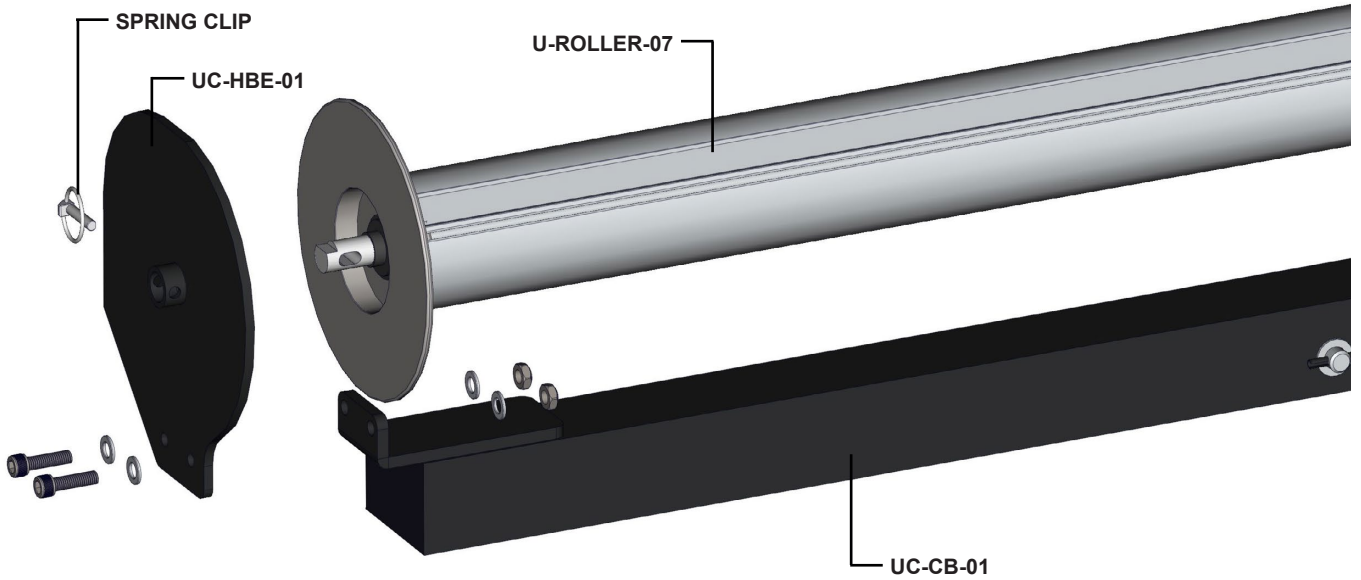

INSTALLING ROLLERBAR

INSTALLATION DE ROLLERBAR | INSTALLATION DER ROLLLEISTE



	M12 x 40 BOLT	x 4
	M12 NUT	x 4
	M12 WASHER	x 8

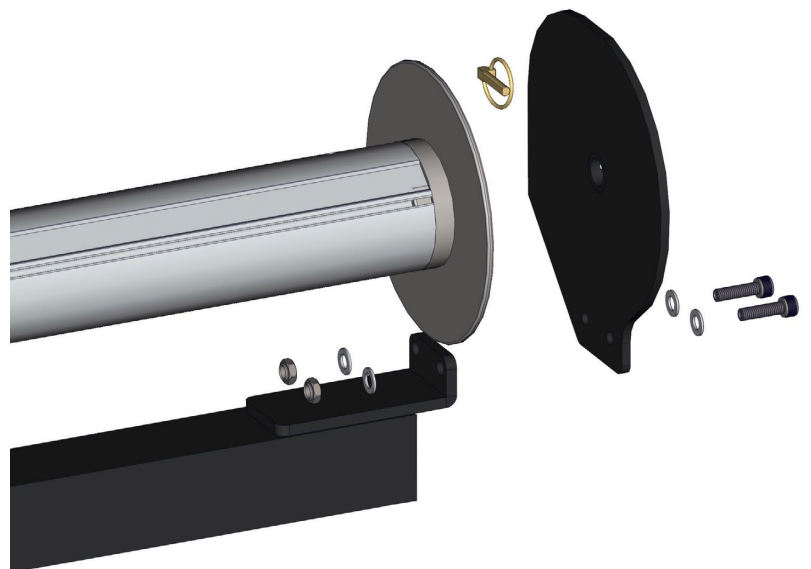

INSTALLING CROSSBAR INSERTS



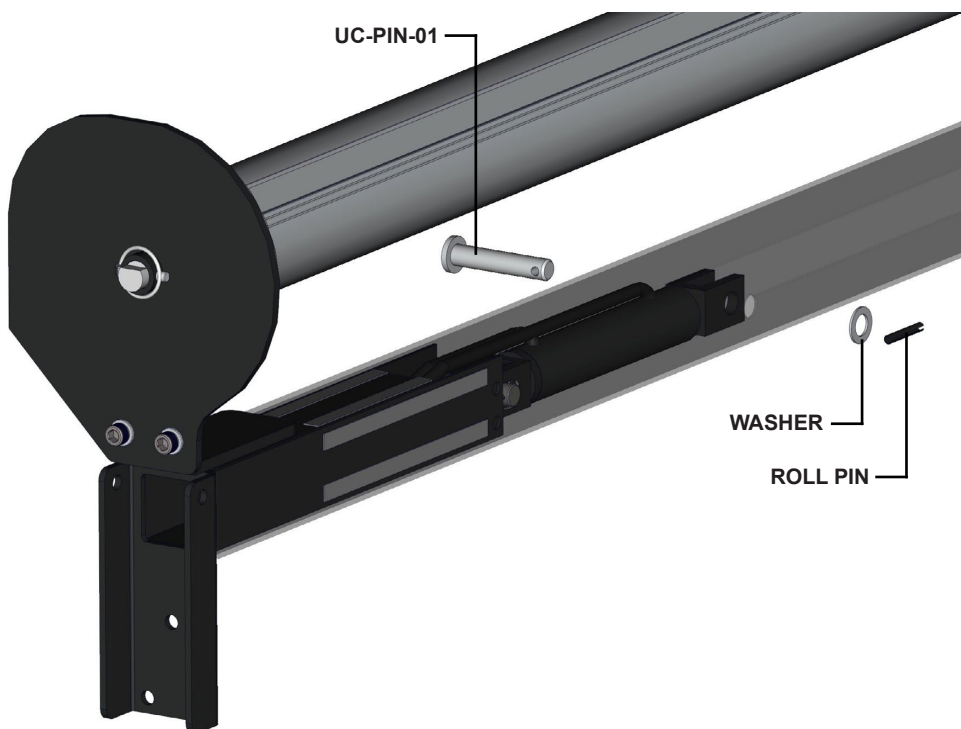
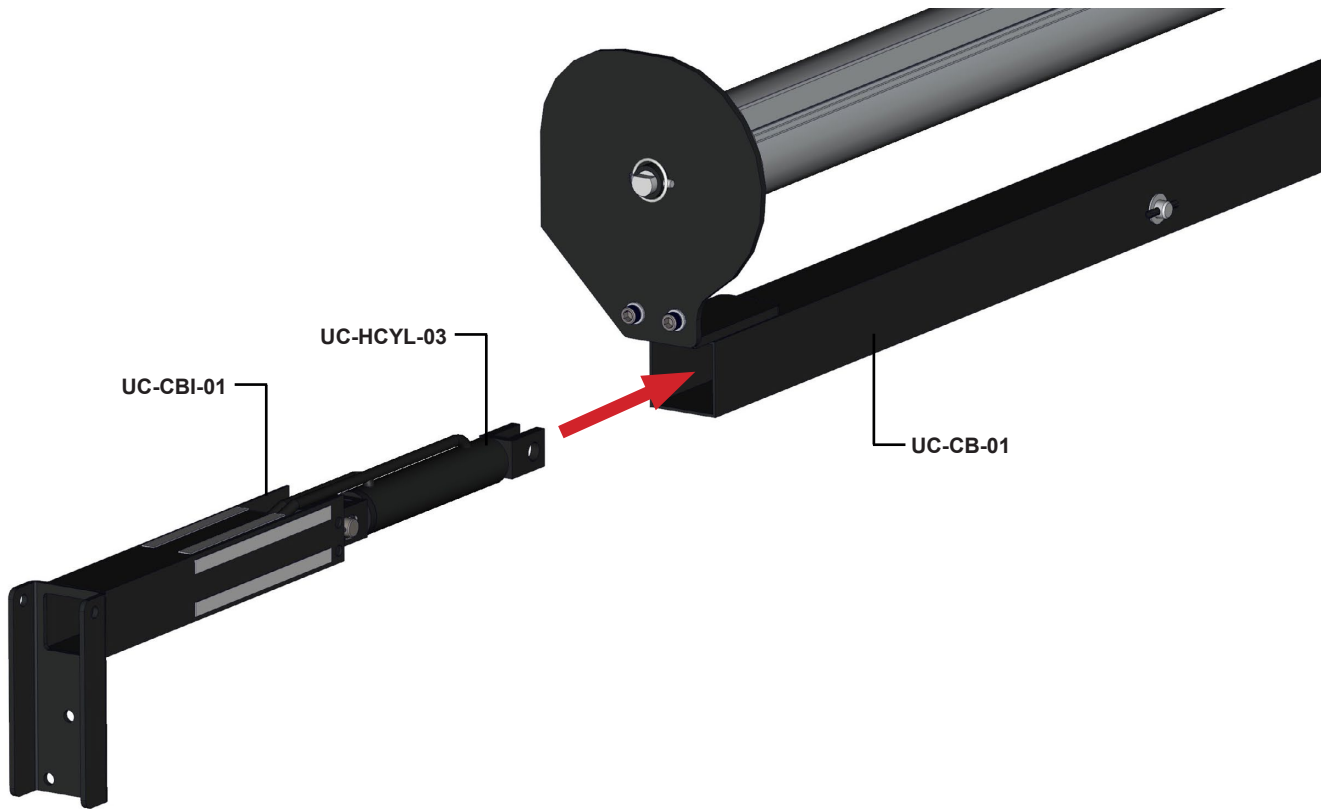

INSTALLATION D'INSERTS | INSTALLATION DE ROLLERBAR



INSTALLING CROSSBAR

INSTALLATION DE LA BARRE TRANSVERSALE | INSTALLATION DER CROSSBAR



	M12 x 70 DOME BOLT	x 6
	M12 x 110 SOCKET BOLT	x 2
	M12 NUT	x 8
	M12 WASHER	x 16

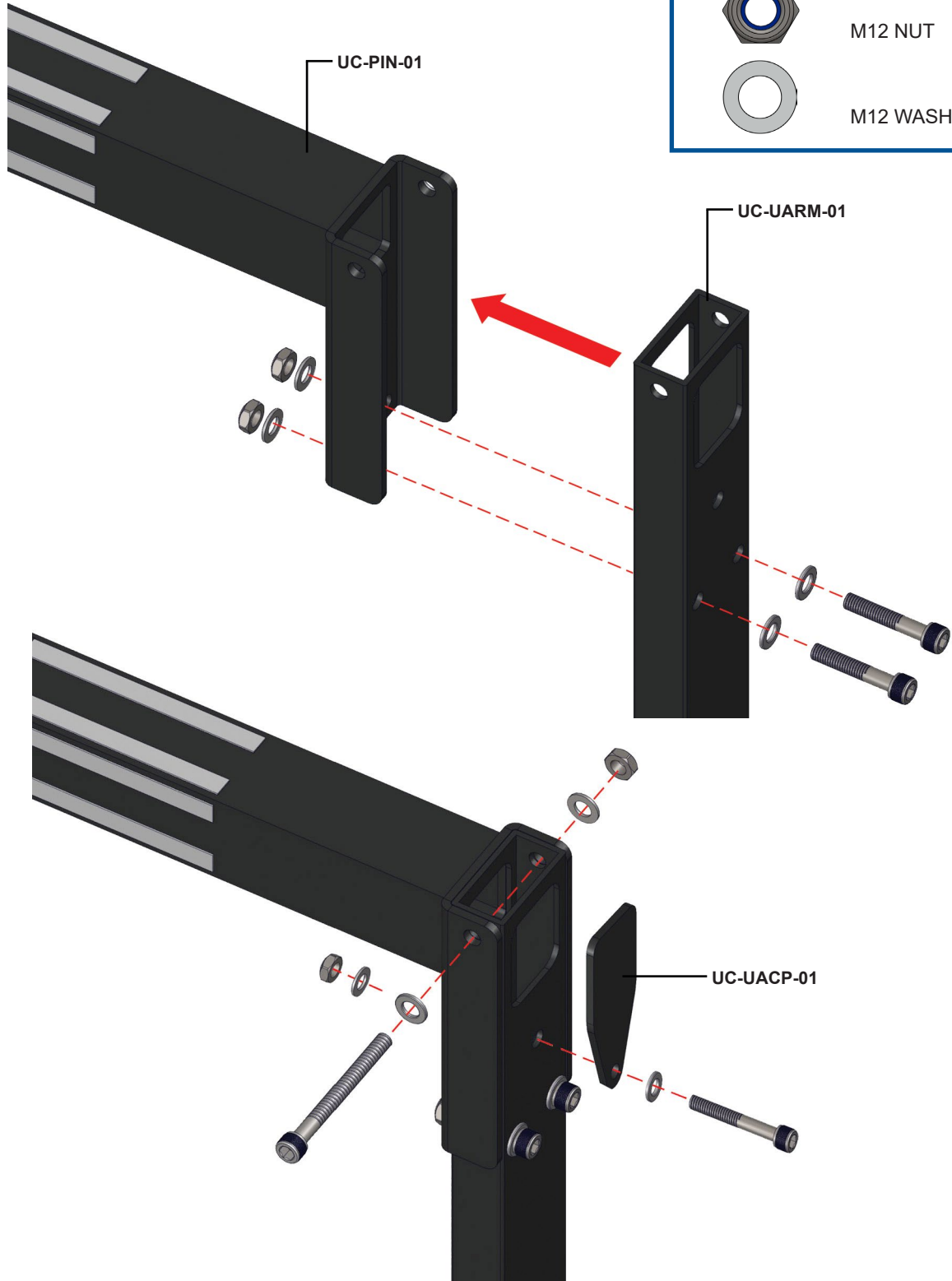

INSTALLING HEADBOARD LEGS

INSTALLATION DES JAMBES | INSTALLATION DER BEINE



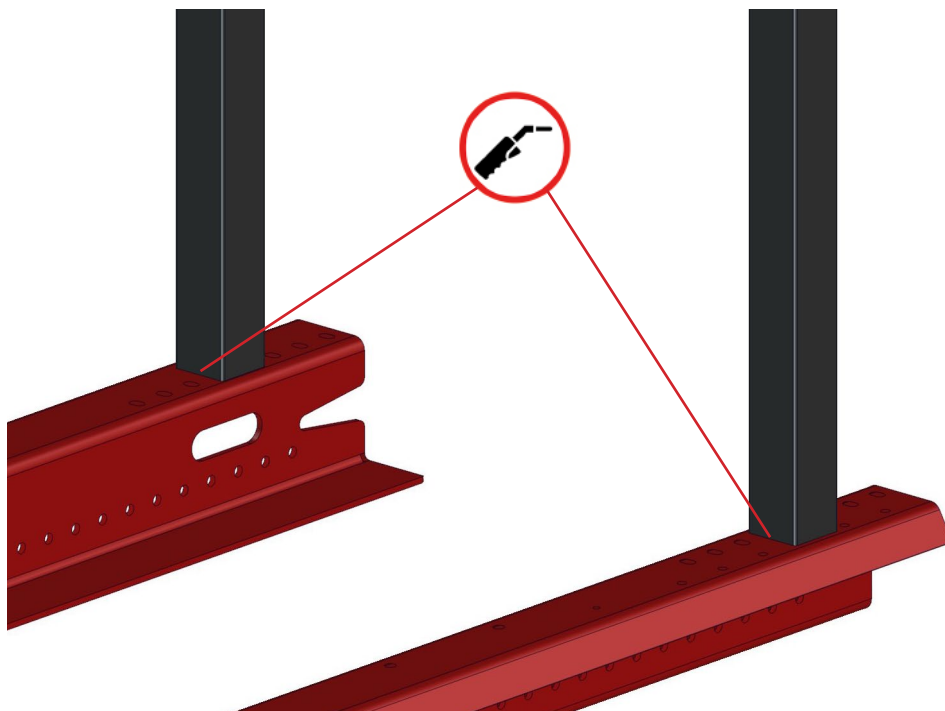
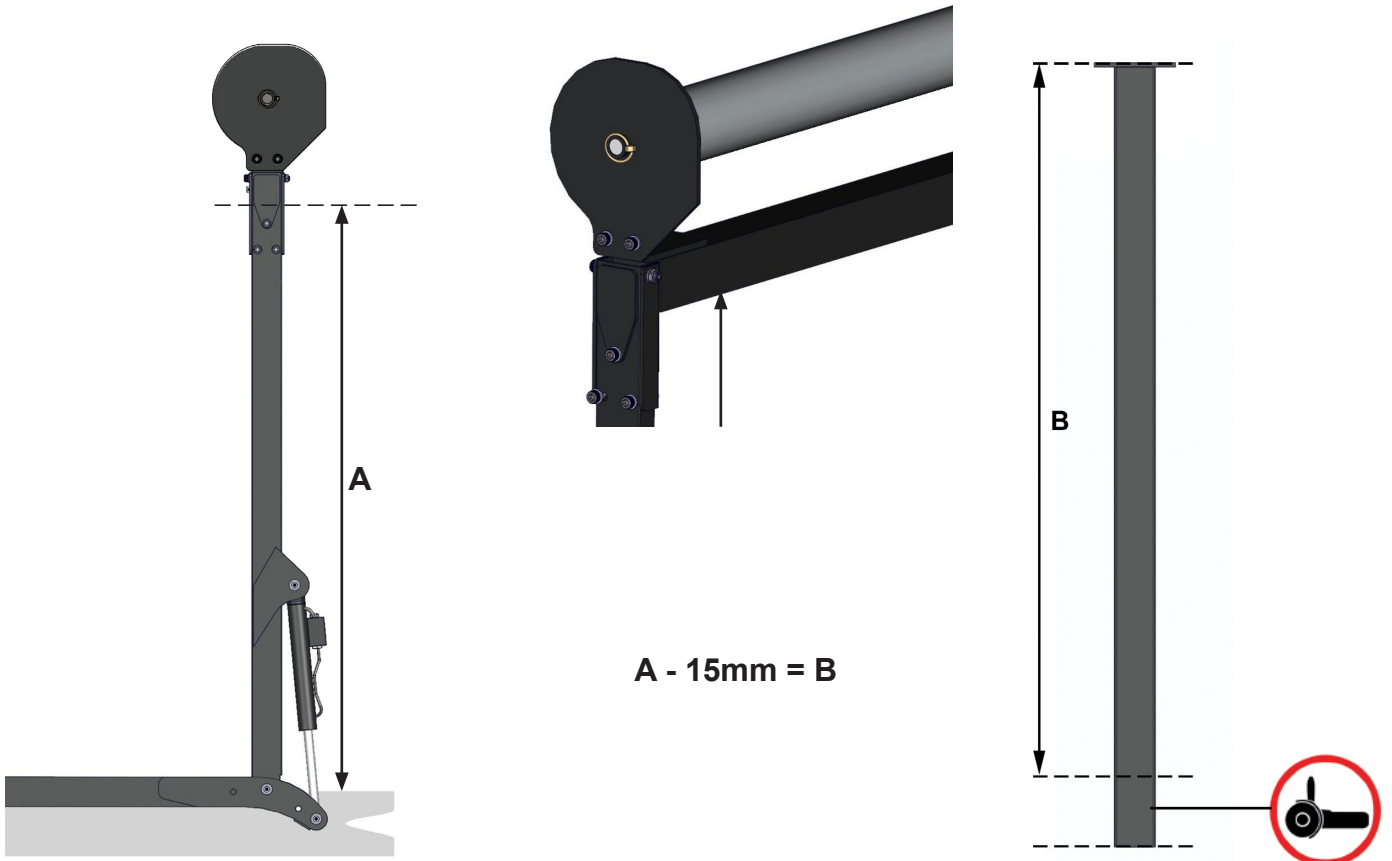

- IF KIT IS SUPPLIED WITH LEG MOUNTS - SKIP THIS STEP
- SI LE KIT EST FOURNI AVEC DES SUPPORTS DE JAMBE - SAUTEZ CETTE ÉTAPE
- WENN DAS KIT MIT BEINHALTERUNGEN KOMMT - ÜBERSPRINGEN SIE DIESEN SCHRITT



OPTIONAL HEADBOARD LEG MOUNT - 1

INSTALLATION DU SUPPORT DE JAMBE DE TÊTE DE TÊTE - 1 | EINBAU DER KOPFTEILBEINHALTERUNG - 1



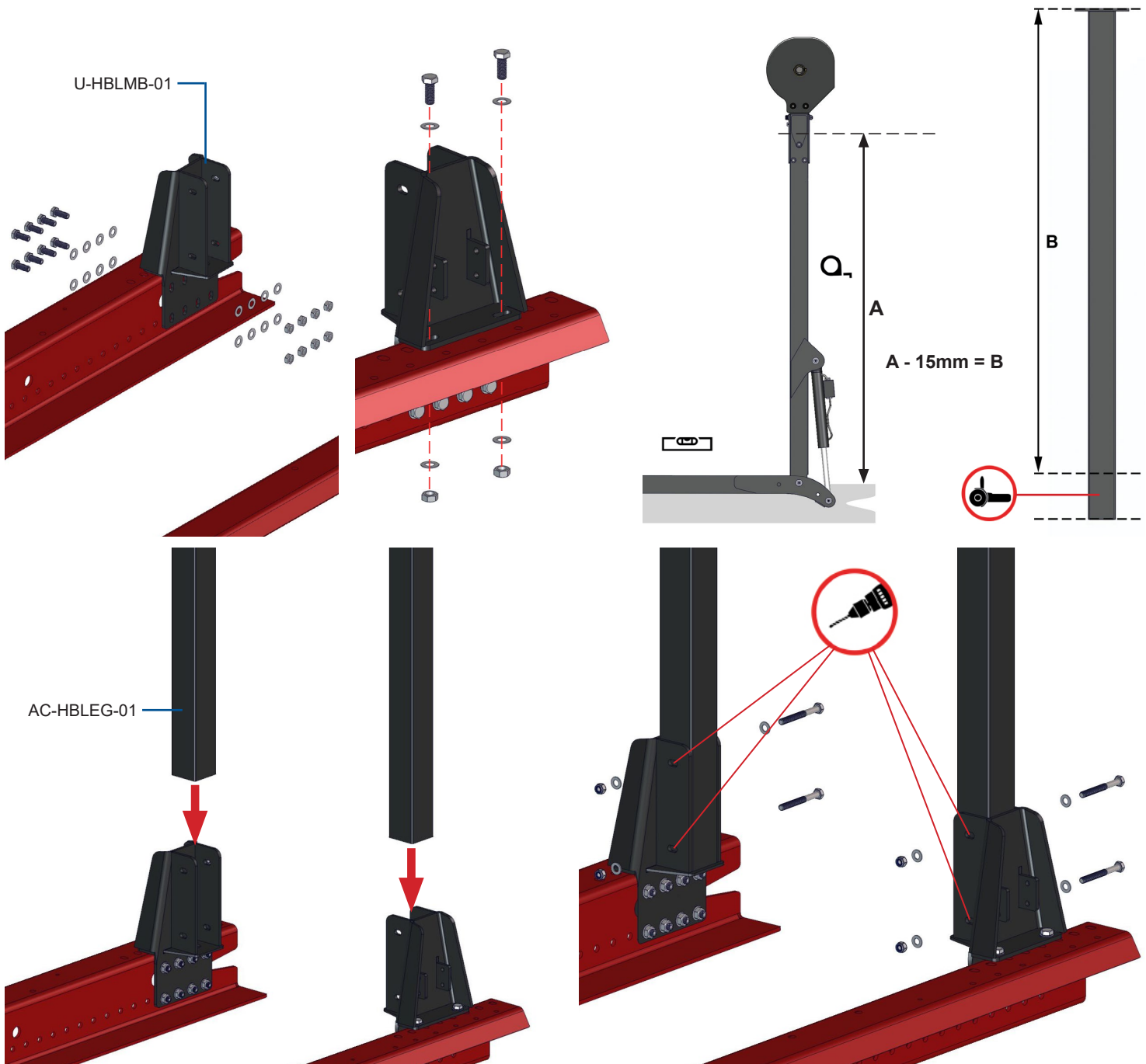

	M12 x 120 SOCKET	x 4
	M12 NUT	x 4
	M12 WASHER	x 8





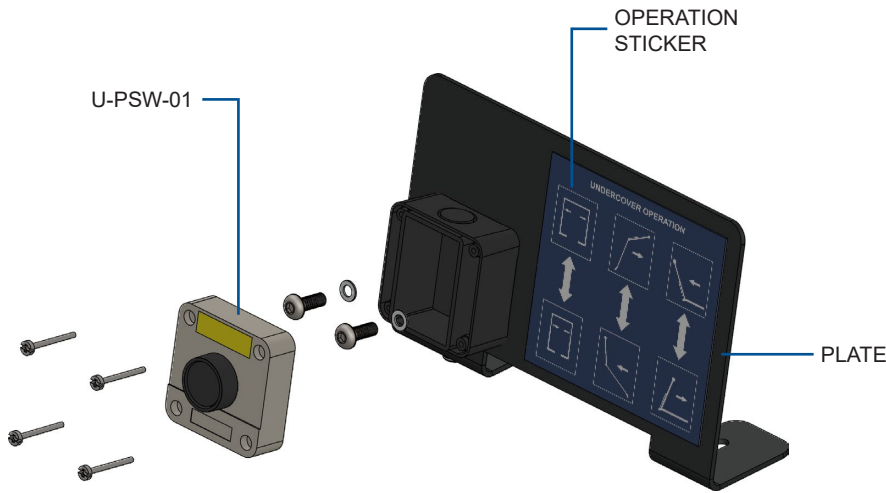

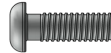
OPTIONAL VALVE MOUNT BRACKET

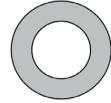
INSTALLATION DU SUPPORT DE JAMBE DE TÊTE DE TÊTE - UNI | EINBAU DER KOPFTEILBEINHALTERUNG - UNI



	M5 x 20 DOME BOLT	x 2
	M5 NYLOC	x 2
	M5 WASHER	x 4

	M8 x 25 DOME BOLT	x 2
	M8 x 60 DOME BOLT	x 2
	M10 NUT	x 4
	M10 WASHER	x 8

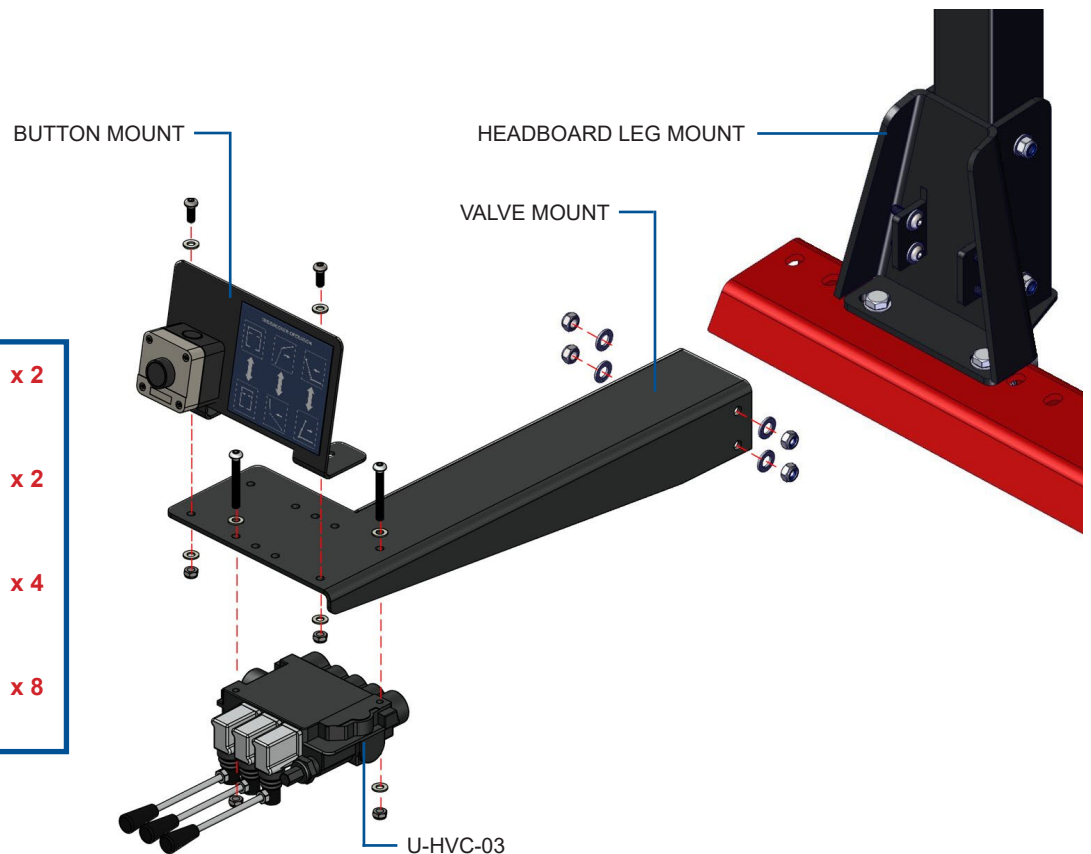

OPTIONAL HEADBOARD LEG MOUNT - 2

INSTALLATION DU SUPPORT DE JAMBE DE TÊTE DE LIT - 2 | EINBAU DER KOPFTEILBEINHALTERUNG - 2

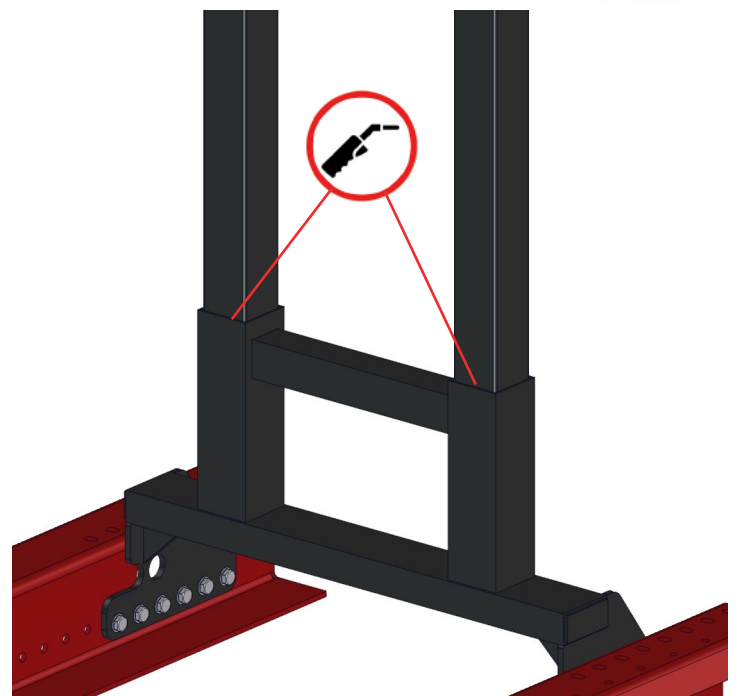
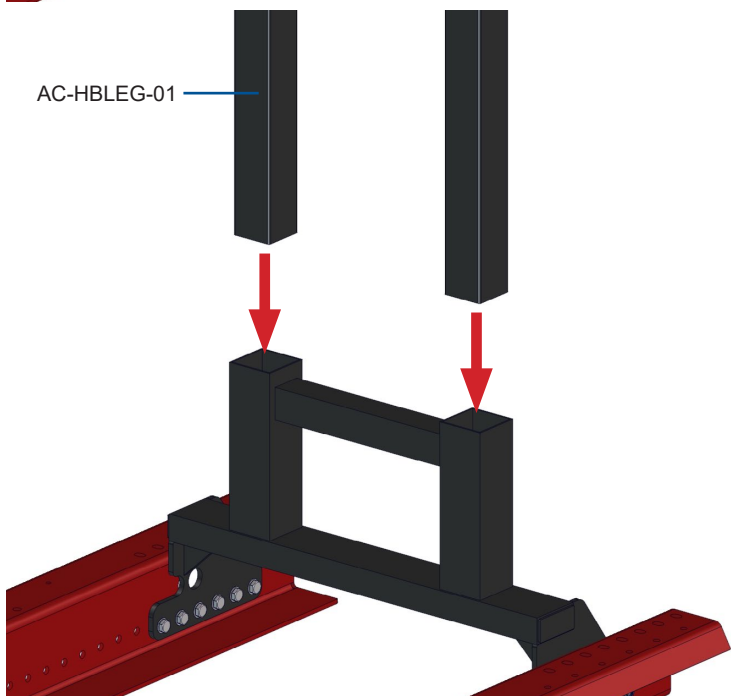
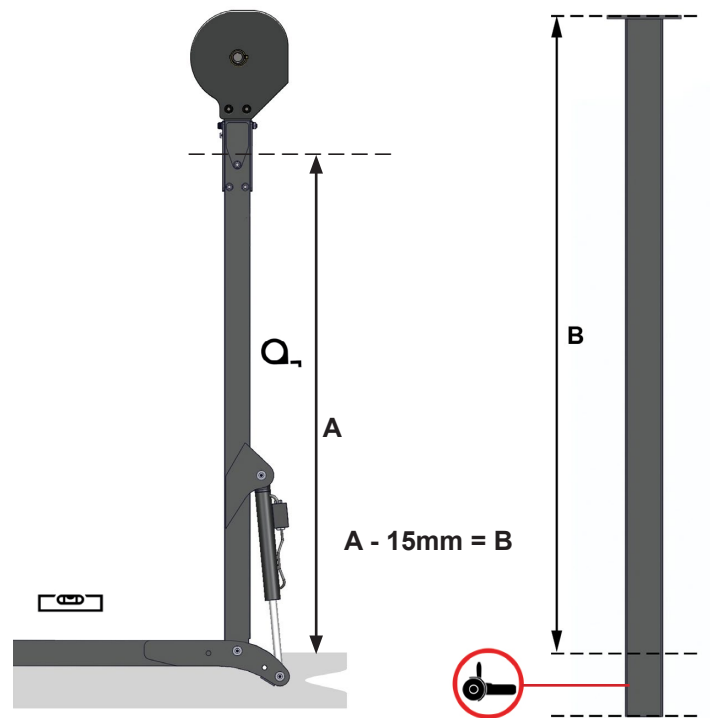
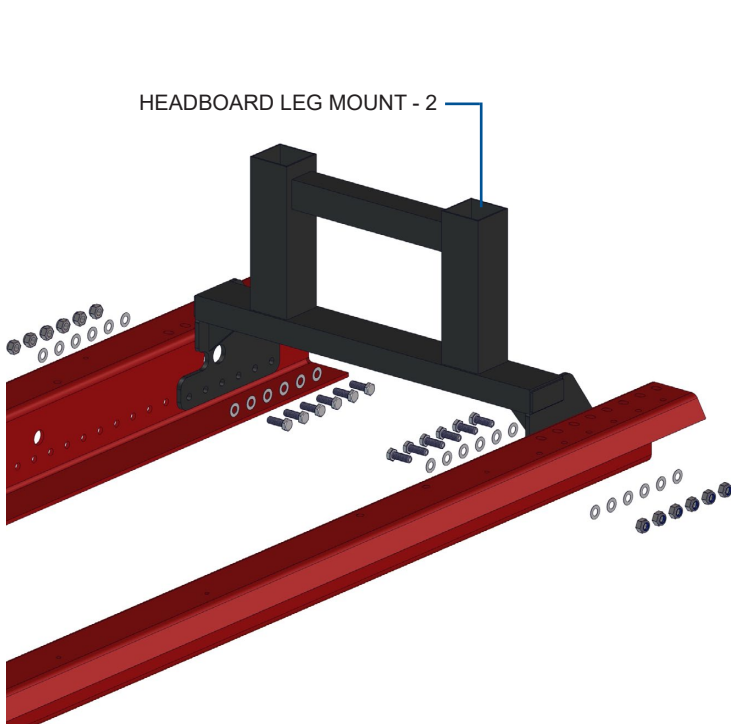

INSTALLING HEADBOARD

INSTALLATION DU HEADBOARD | INSTALLATION DES HEADBOARD

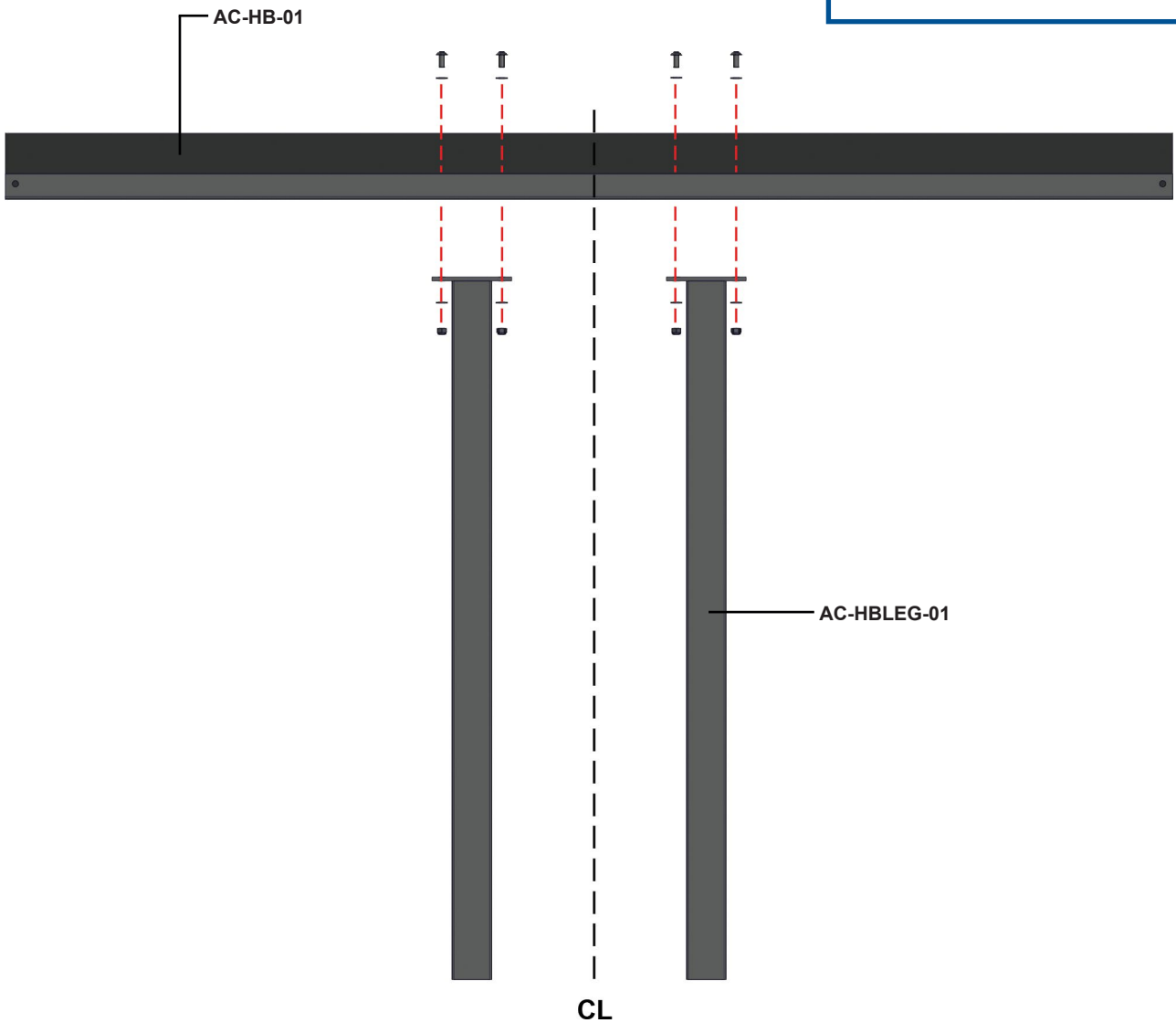
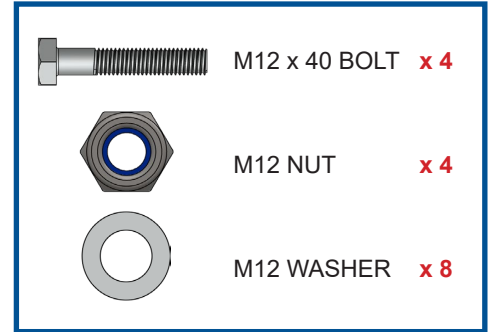

INSTALLING PUMP

INSTALLATION DE LA POMPE | INSTALLIEREN VON PUMPE



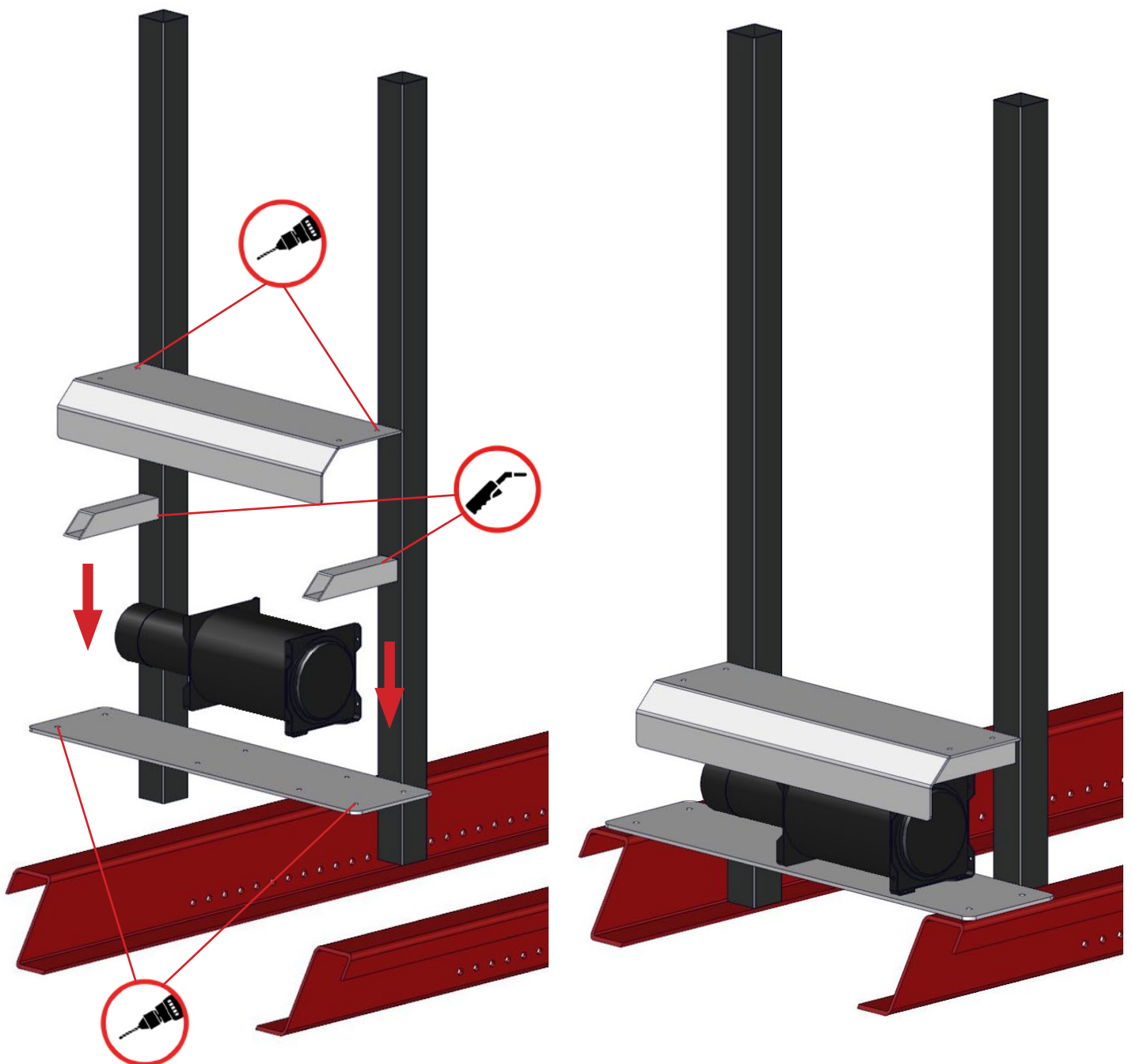

- Fabricate suitable bracket to mount pump as shown in example
- Fabriquer le support approprié pour monter la pompe comme indiqué dans l'exemple
- Herstellung geeigneter Halterung zur Montage der Pumpe, wie im Beispiel gezeigt



OPTIONAL PUMP MOUNT - INSTALLATION

INSTALLATION DU MONT DE POMPE | INSTALLIEREN VON PUMP MOUNT



	M12 x 110 SOCKET	x 8
	M12 NUT	x 8
	M12 WASHER	x 16

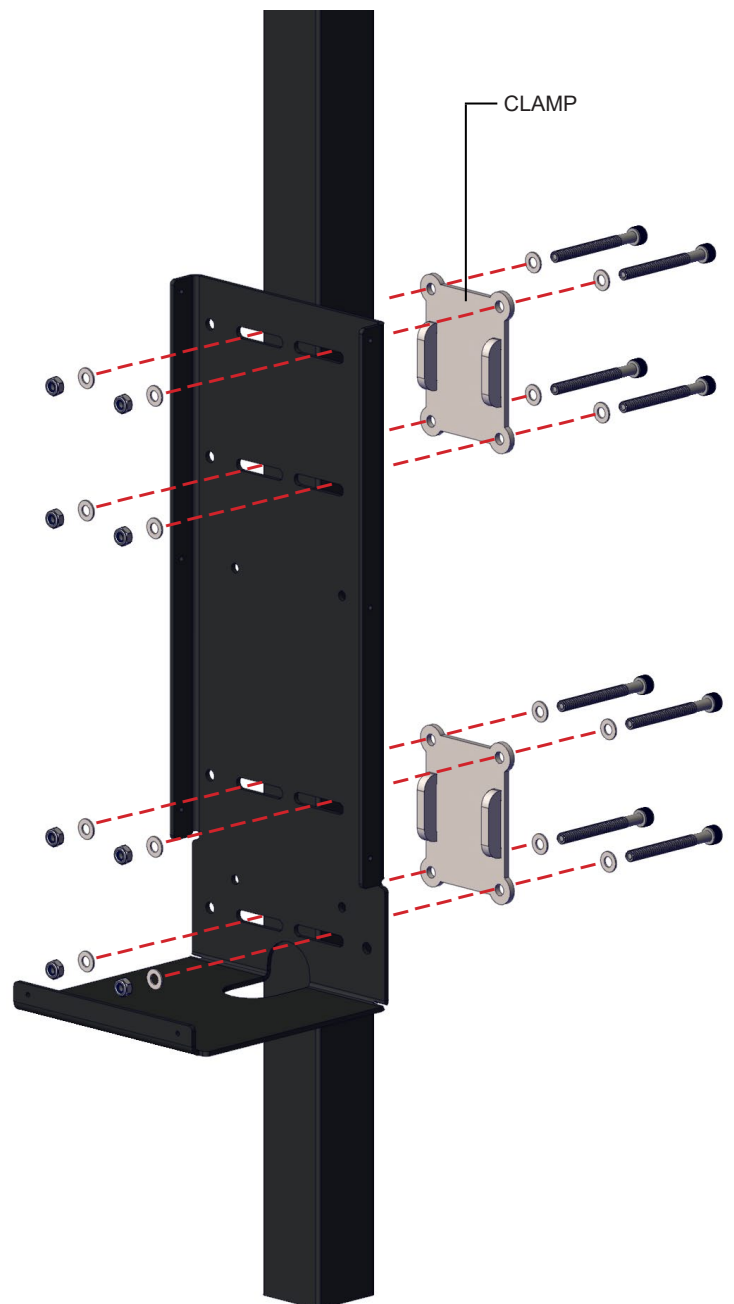
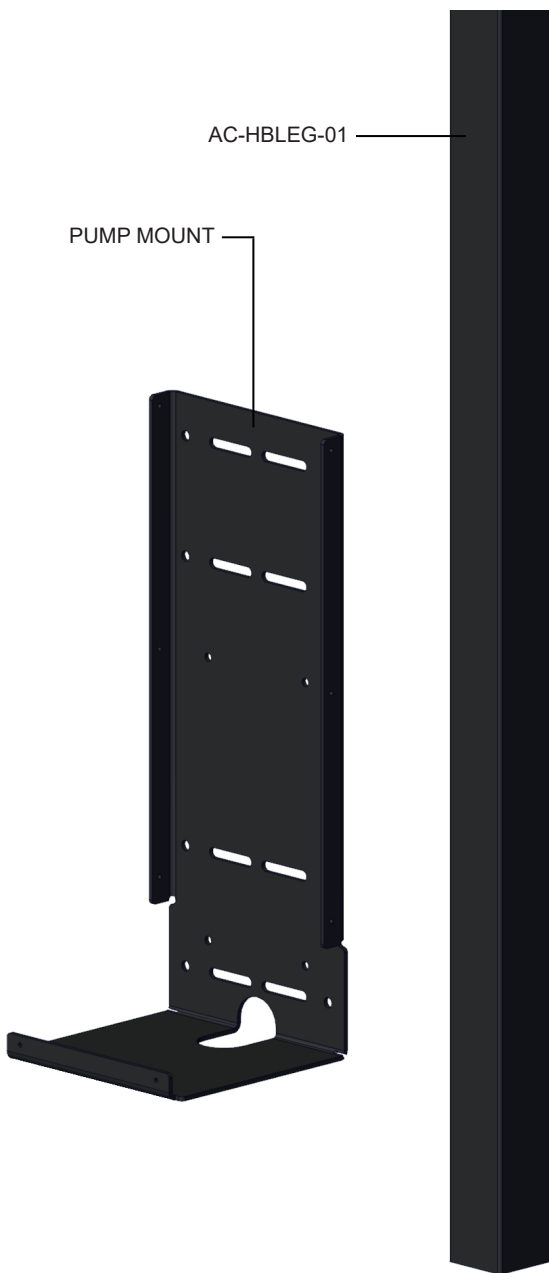

INSTALLING PUMP

INSTALLATION DU MONT DE POMPE | INSTALLIEREN VON PUMP MOUNT

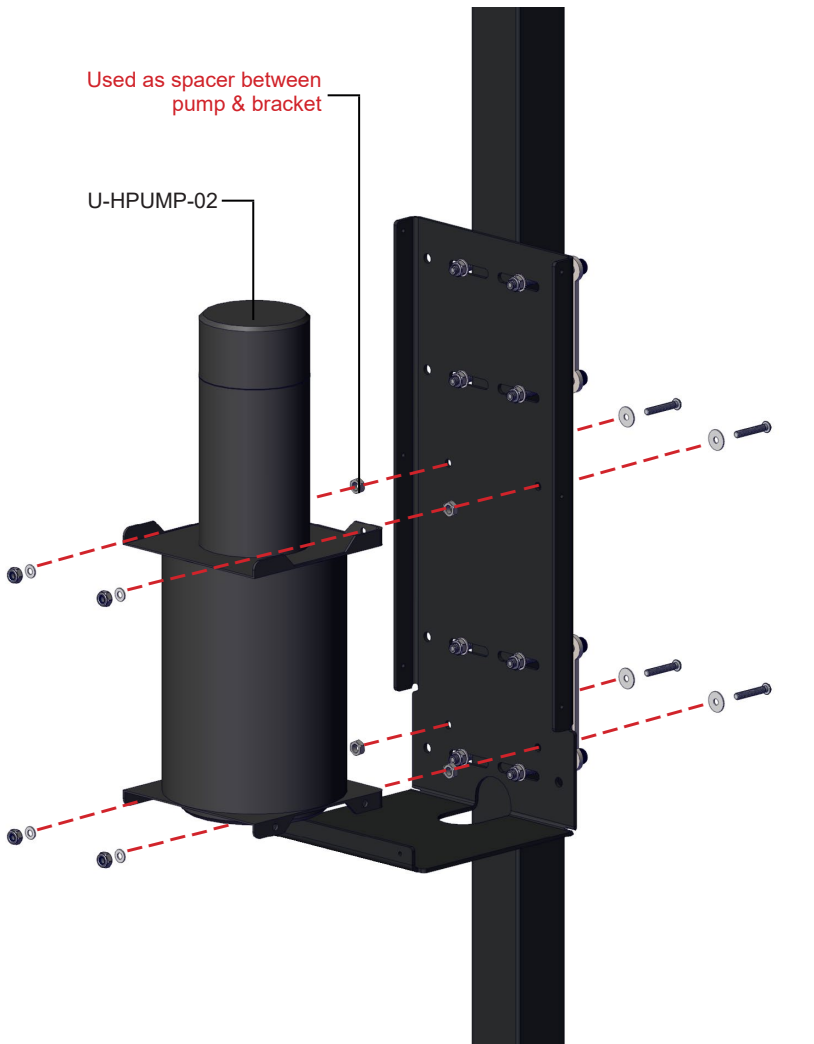

	M8 x 35 DOME BOLT	x 4
	M12 NUT	x 4
	M8 WASHER	x 8
	M8 NYLOCK NUT	x 4
	REPAIR WASHER	x 4

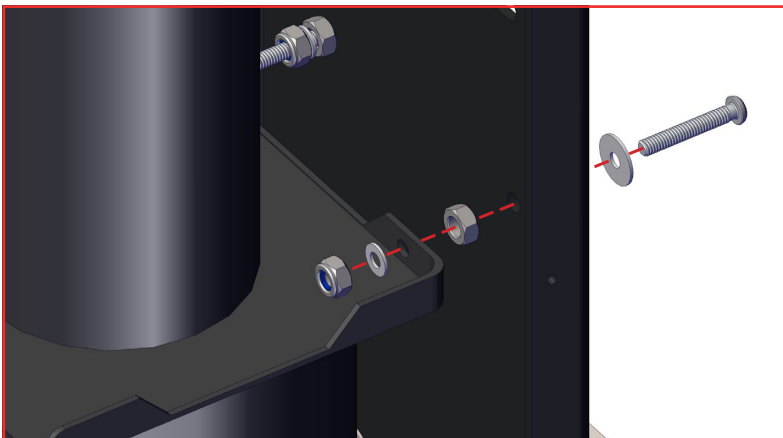

INSTALLING PUMP COVER

INSTALLATION DU MONT DE POMPE | INSTALLIEREN VON PUMP MOUNT





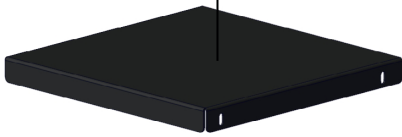

PUMP COVER LID



PUMP COVER



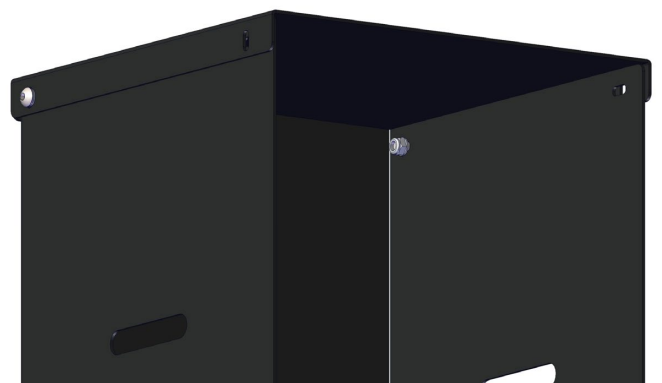
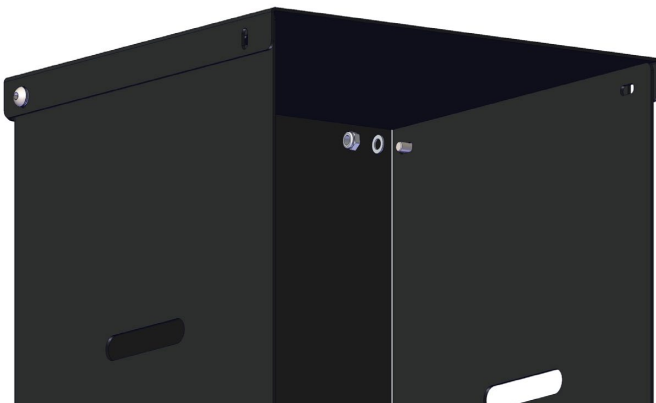

	M6 x 20 DOME BOLT	x 2
	M6 NUT	x 2
	M6 WASHER	x 4
	M6 SPRING WASHER	x 2



INSTALLING PUMP COVER

INSTALLATION DU MONT DE POMPE | INSTALLIEREN VON PUMP MOUNT



	M6 x 20 DOME BOLT	x 8
	M6 WASHER	x 8
	M6 SPRING WASHER	x 8

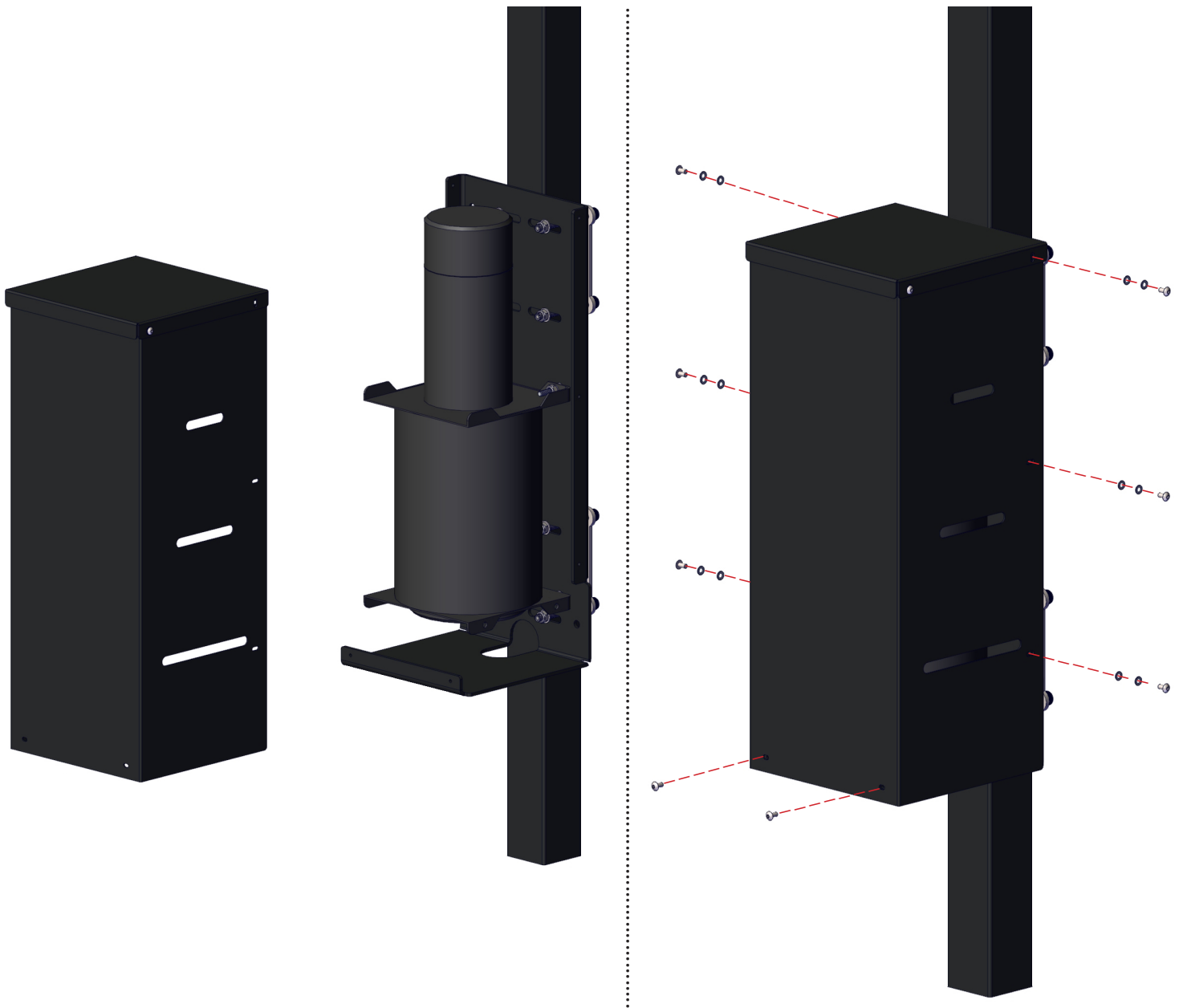

INSTALLING SHEET

INSTALLATION DE TARPAULIN | INSTALLATION VON TARPAULIN

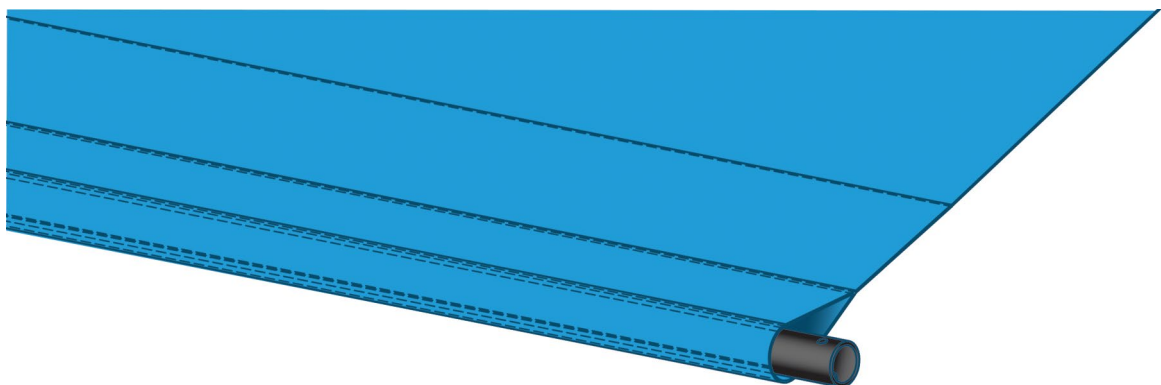
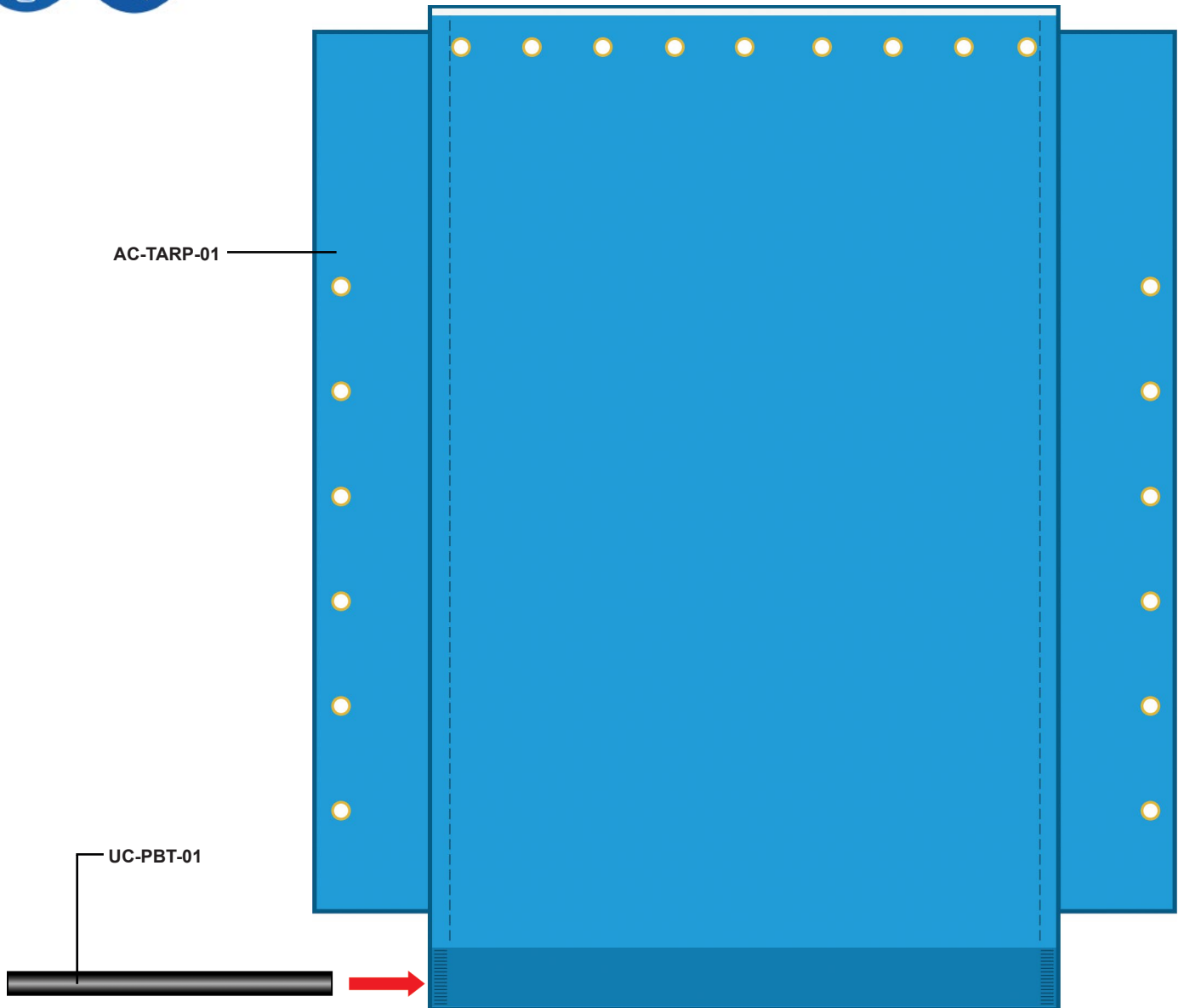

INSTALLING SHEET

INSTALLATION DE TARPAULIN | INSTALLATION VON TARPAULIN



U-ROLLER-07

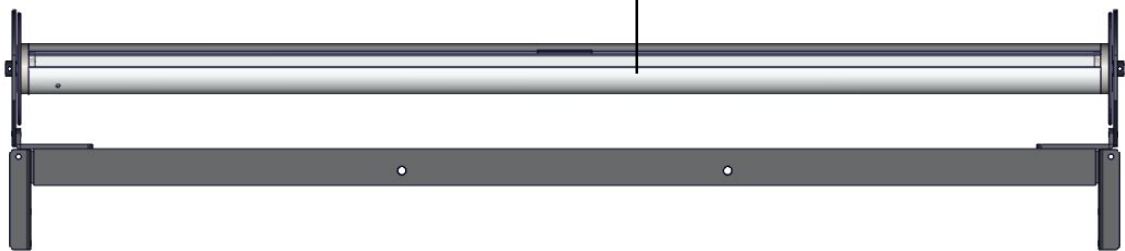

UC-TARP-01

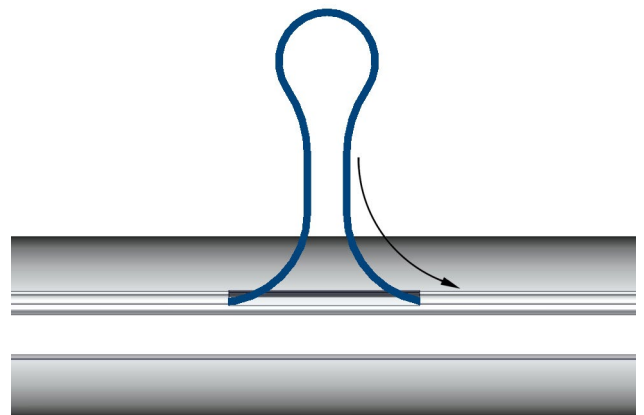
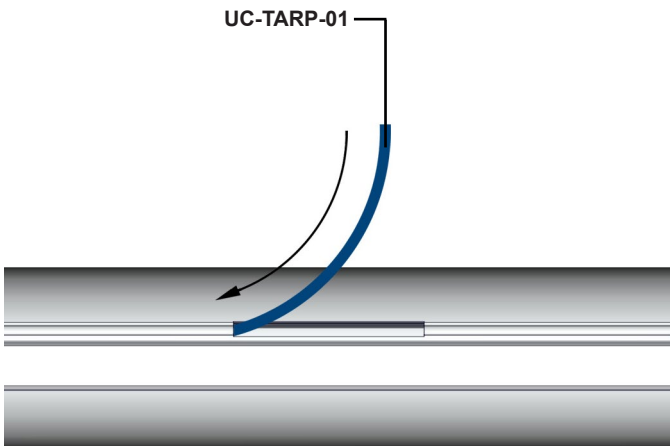

TENSIONING ROLLERBAR

INSTALLATION DE TARPAULIN | INSTALLATION VON TARPAULIN



- EXERCISE CAUTION WHEN WORKING WITH SPRING TENSION
- FAIRE PREUVE DE PRUDENCE LORSQUE VOUS TRAVAILLEZ AVEC DES RESSORTS
- WALTEN SIE VORSICHT LASSEN BEI DER ARBEIT MIT QUELLEN

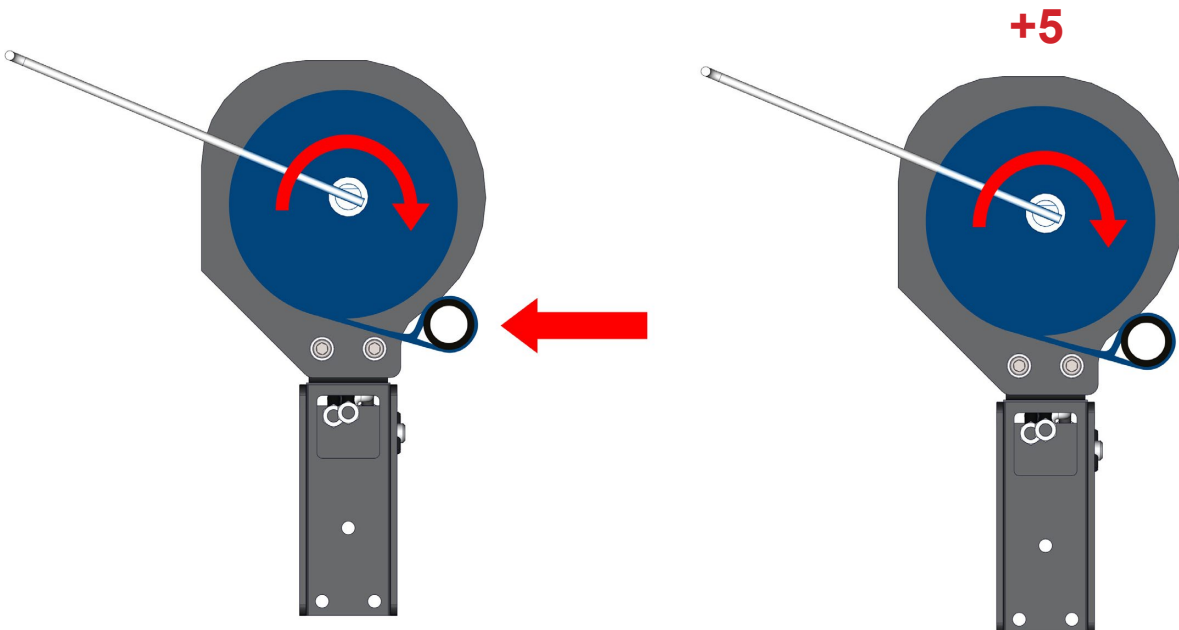
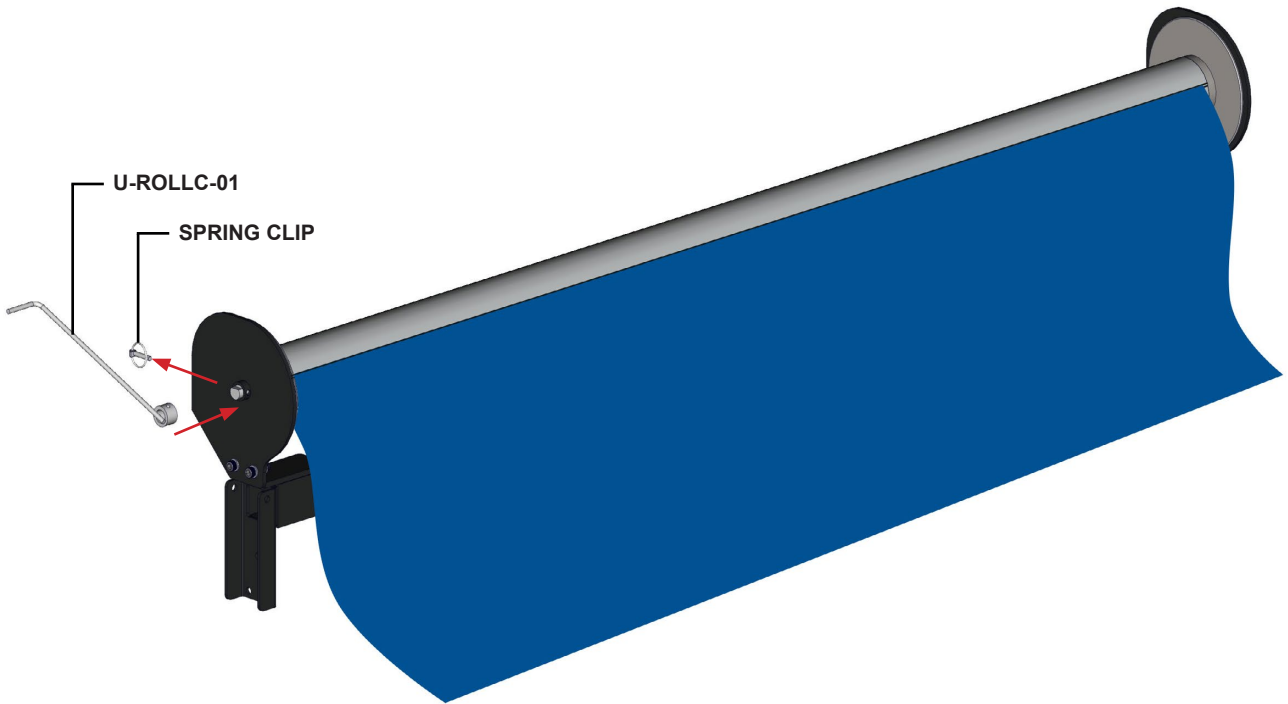

TENSIONING ROLLERBAR

TENSIONING ROLLERBAR | TENSIONING ROLLERBAR



- EXERCISE CAUTION WHEN WORKING WITH SPRING TENSION
- FAIRE PREUVE DE PRUDENCE LORSQUE VOUS TRAVAILLEZ AVEC DES RESSORTS
- WALTEN SIE VORSICHT LASSEN BEI DER ARBEIT MIT QUELLEN

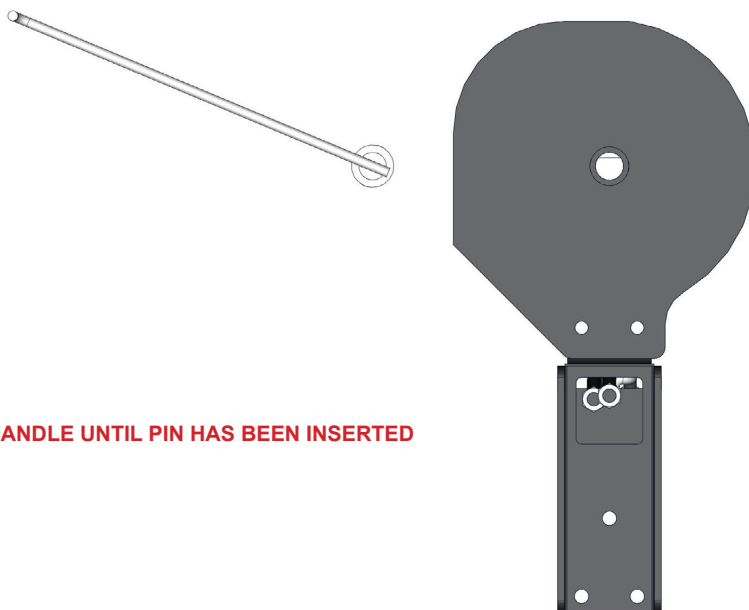
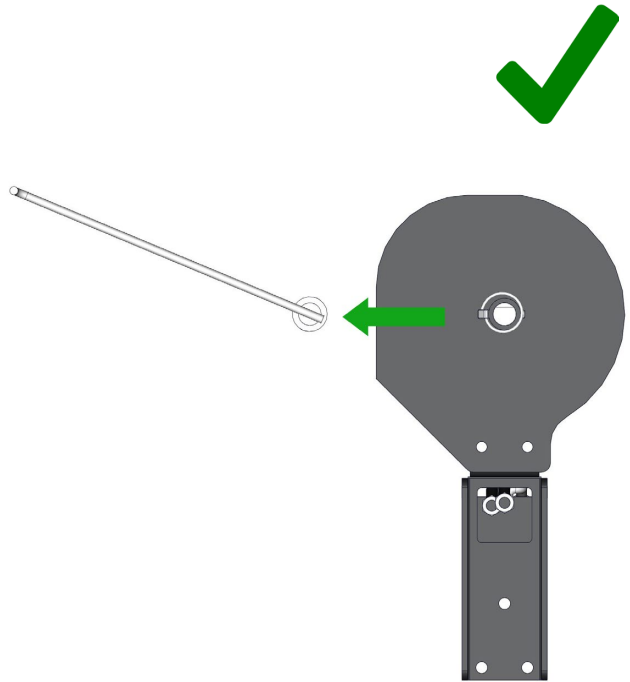
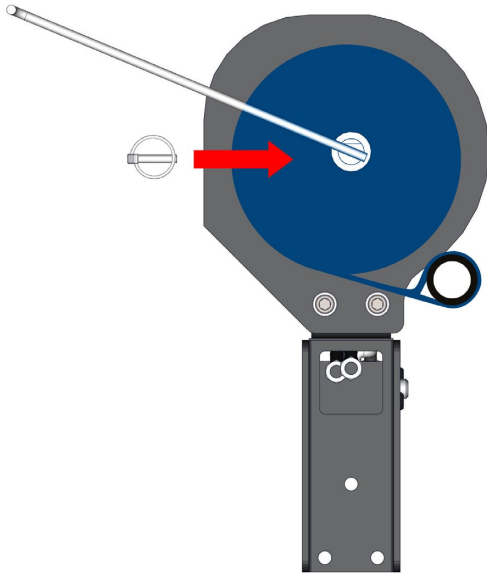

DO NOT REMOVE HANDLE UNTIL PIN HAS BEEN INSERTED

INSTALLING BUFFER ARM

INSTALLING BUFFER ARM | INSTALLING BUFFER ARM

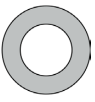

	M10 x 35 DOME BOLT	x 2
	M10 WASHER	x 2

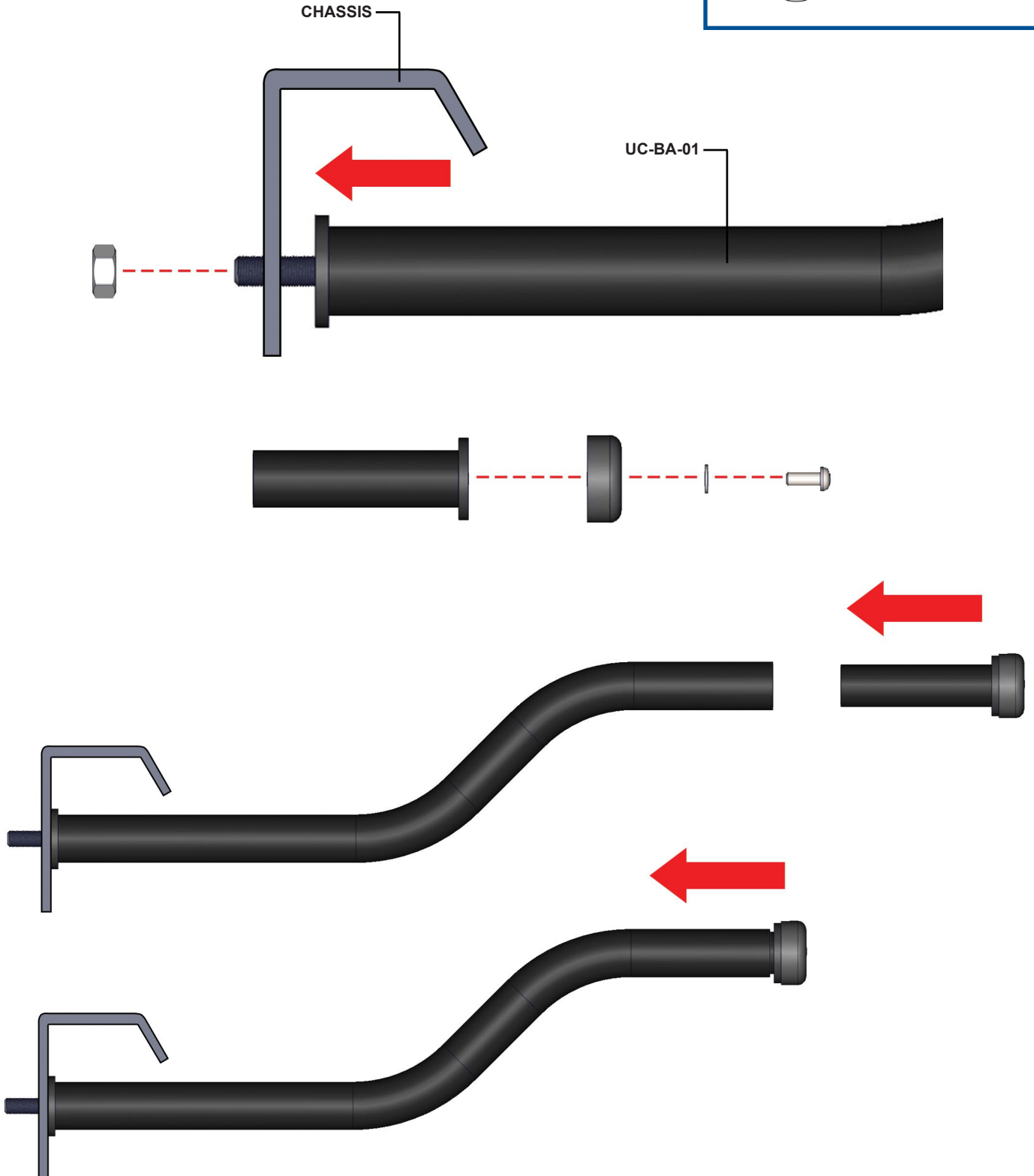

INSTALLING BUFFER ARM

INSTALLING BUFFER ARM | INSTALLING BUFFER ARM

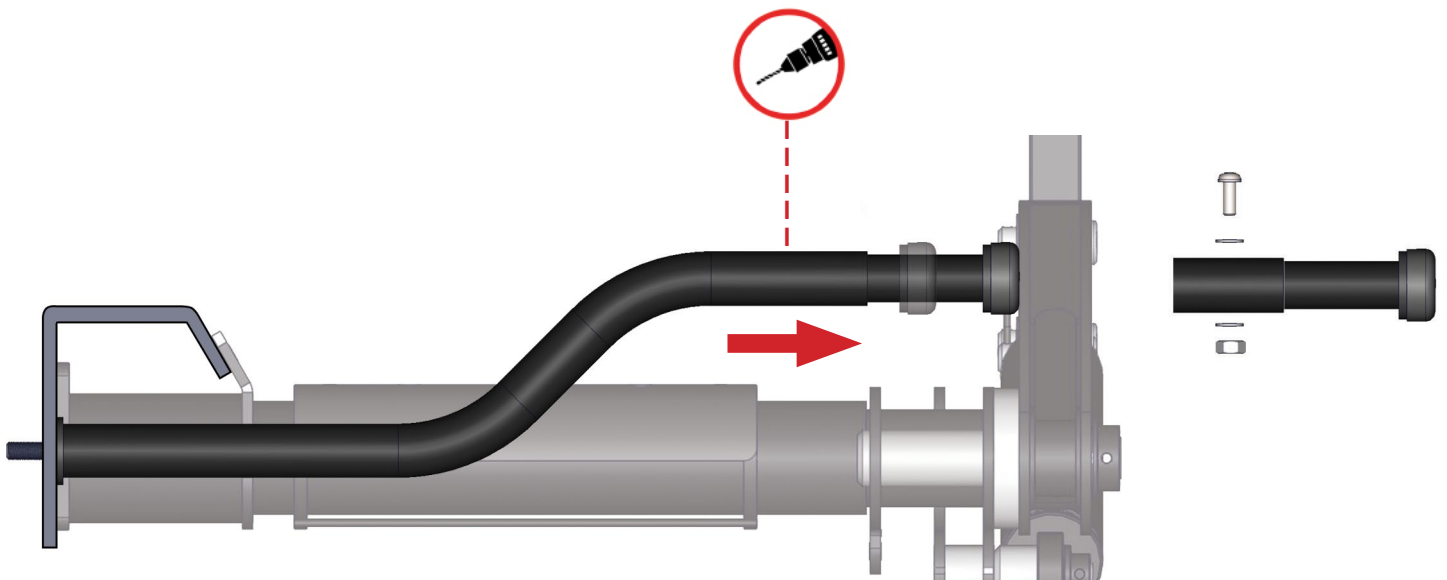
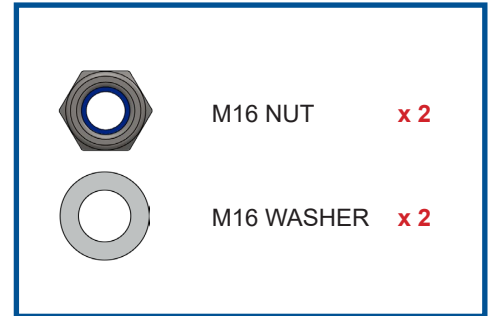
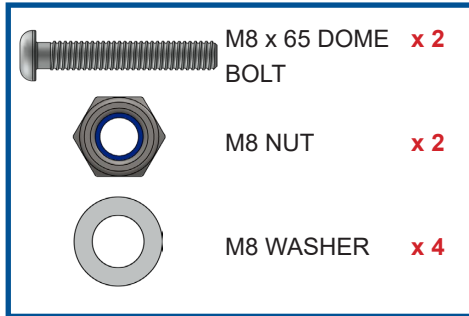

PUMP ELECTRICAL CIRCUIT

CIRCUIT DE POMPE | PUMPENKREISLAUF

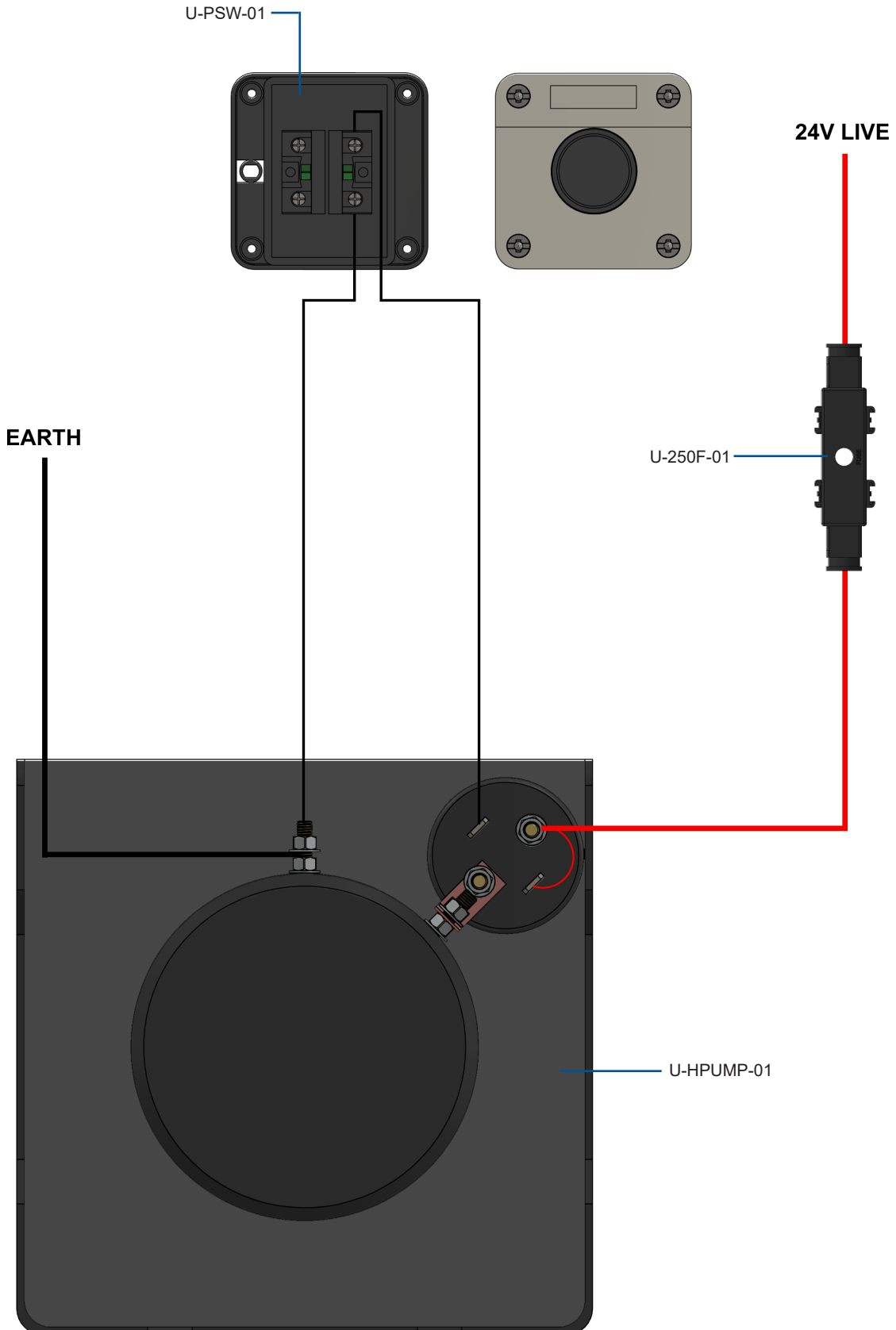

HYDRAULIC DIAGRAM

DIAGRAMME HYDRAULIQUE | HYDRAULISCHES DIAGRAMM

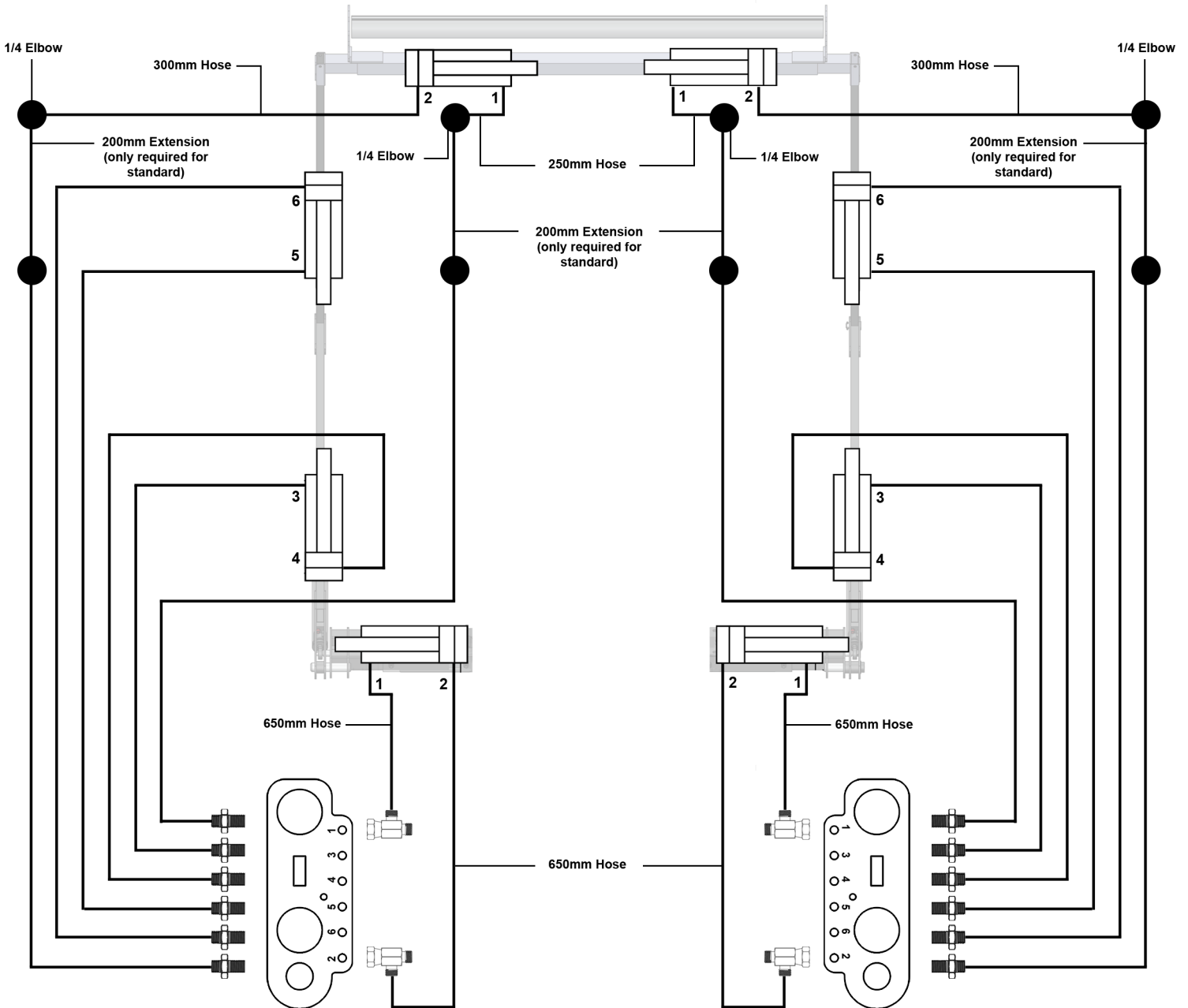

Continued page 45

HYDRAULIC DIAGRAM

DIAGRAMME HYDRAULIQUE | HYDRAULISCHES DIAGRAMM

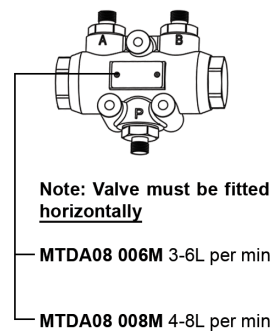
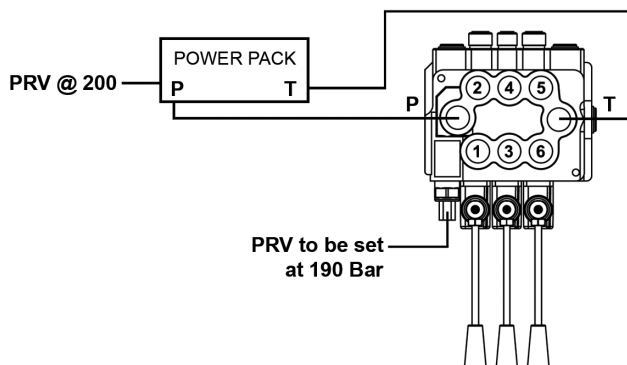
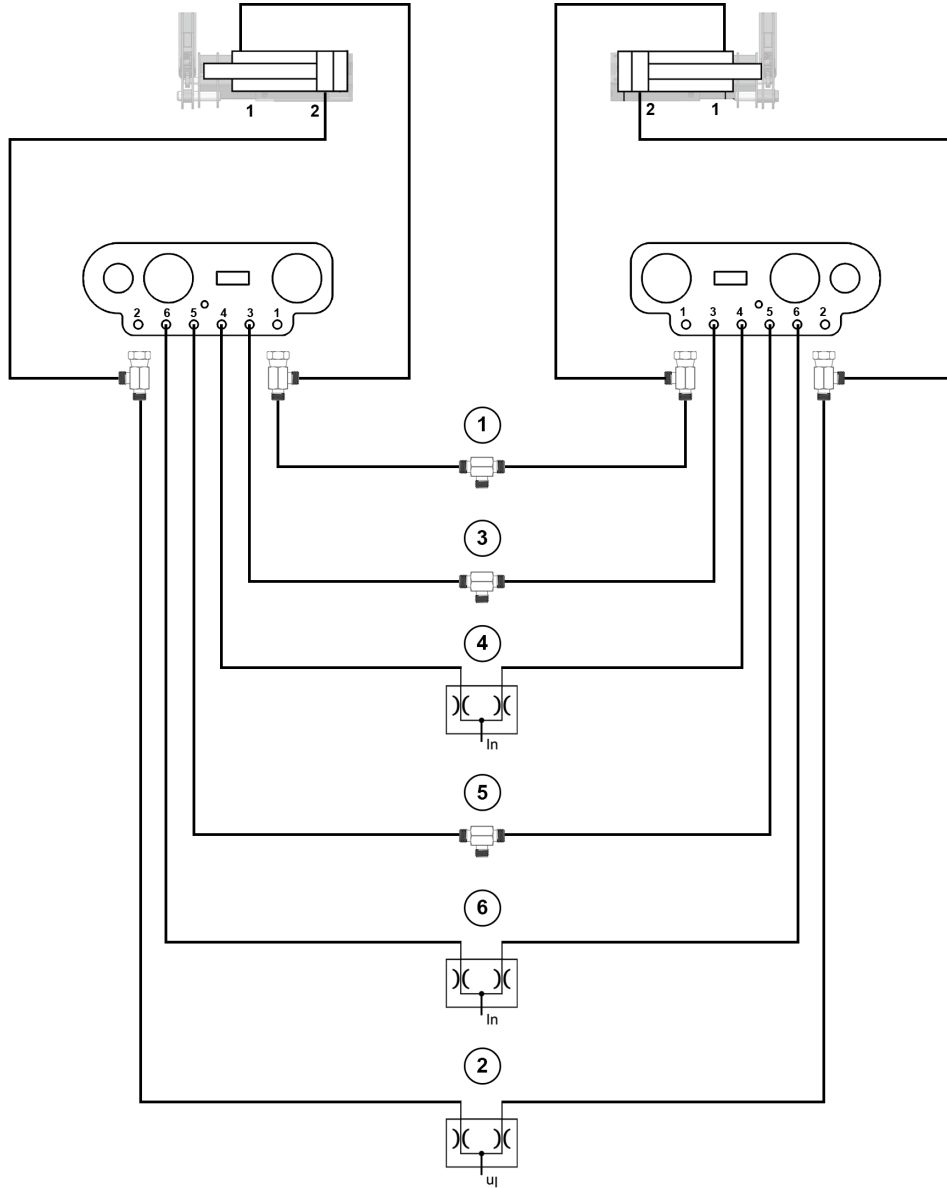

HYDRAULIC VALVE OPERATION

FONCTIONNEMENT DE LA SOUPAPE HYDRAULIQUE | BETRIEB DES HYDRAULIKVENTILS

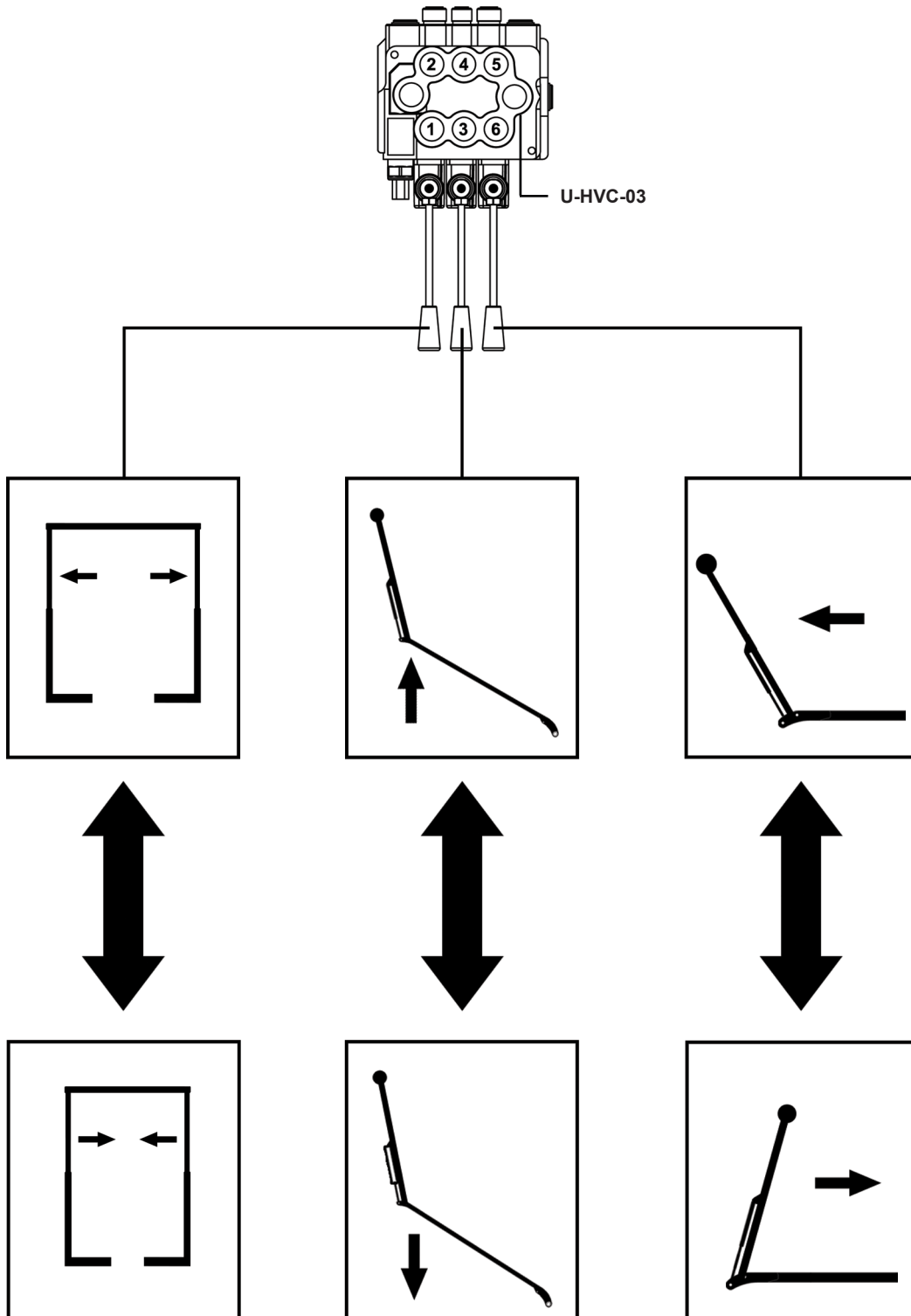

OPERATION - COVERING

FONCTIONNEMENT-RECouvreMENT | OPERATION-COVERING



LOOK! IS IT SAFE?
Regarder! EST-IL SÉCURITAIRE?
Blick! IST IT SAFE?

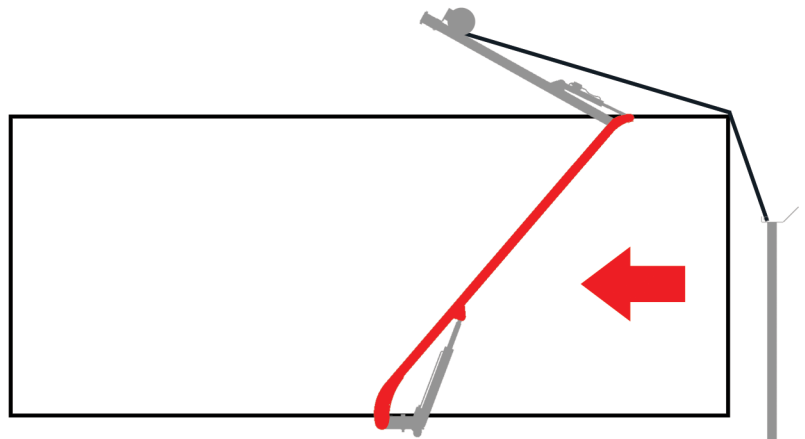
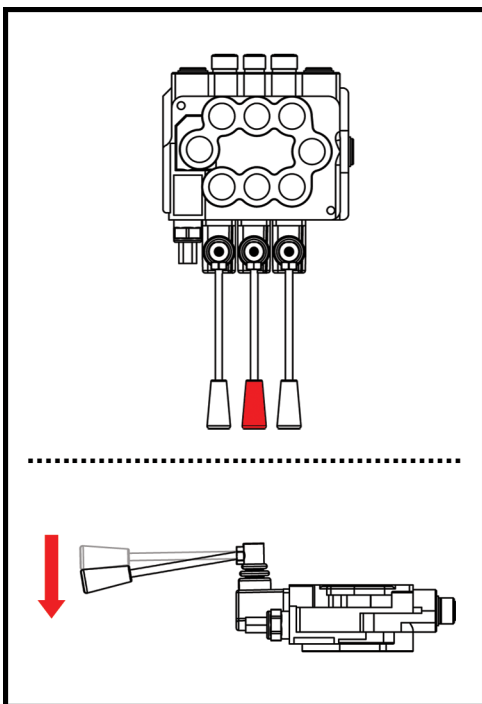
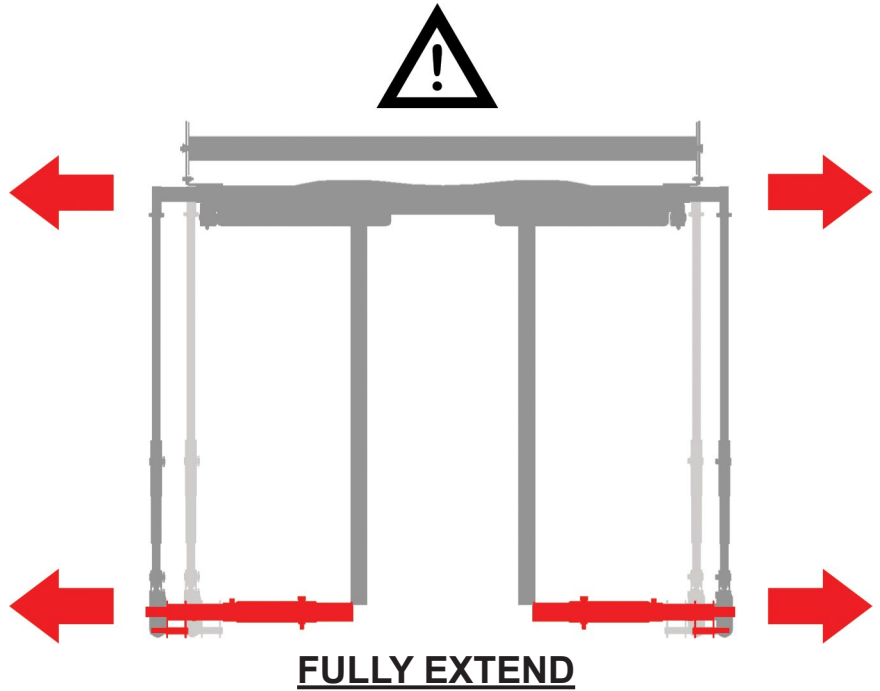
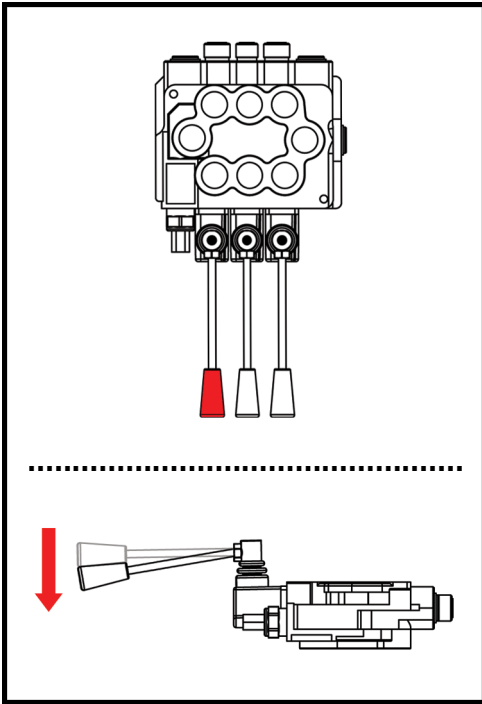

OPERATION - COVERING

FONCTIONNEMENT-RECouvreMENT | OPERATION-COVERING

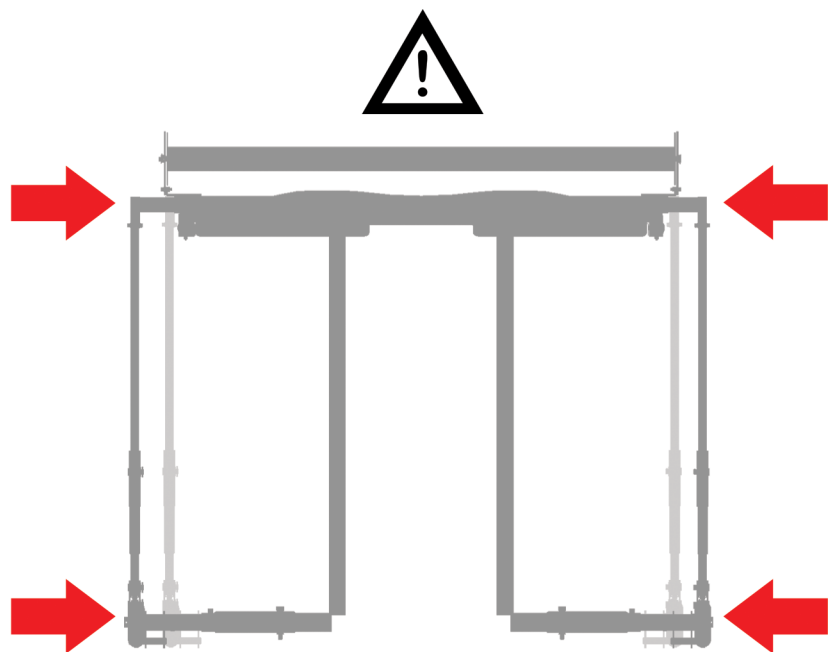
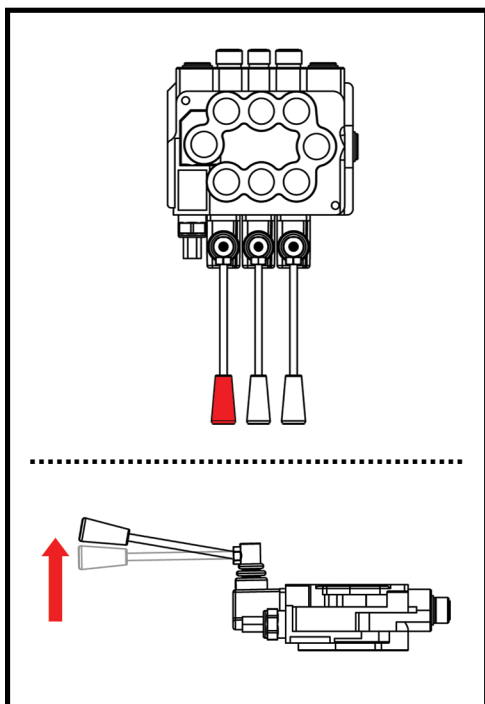
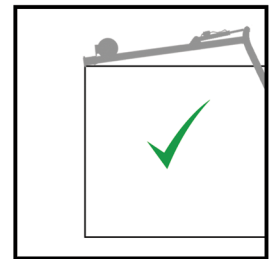
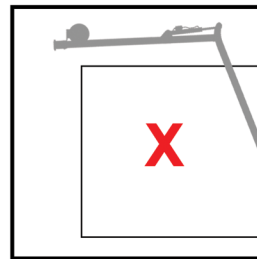
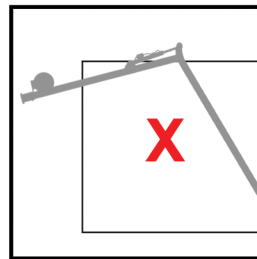
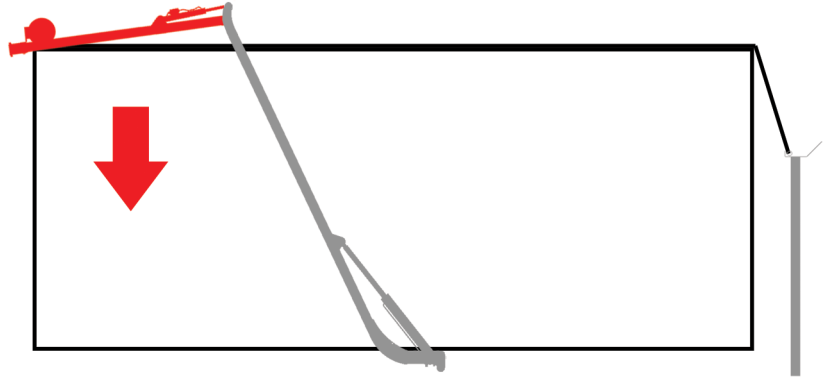
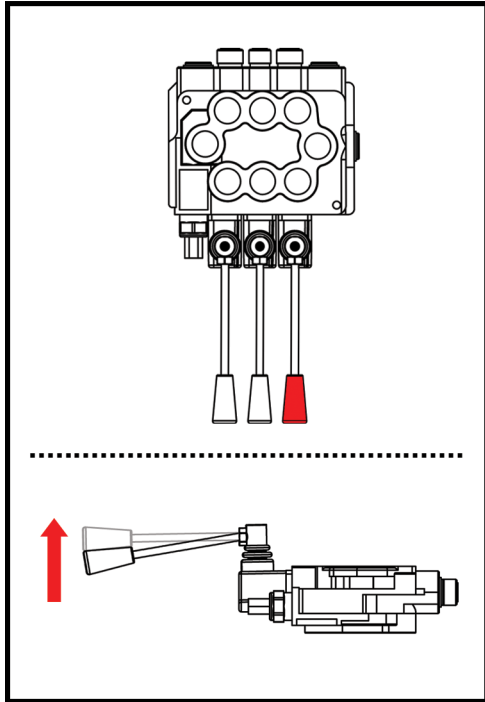

RETRACT TO CONTAINER

OPERATION - UNCOVERING

FONCTIONNEMENT-DÉCOUVRIR | OPERATION - UNCOVERING

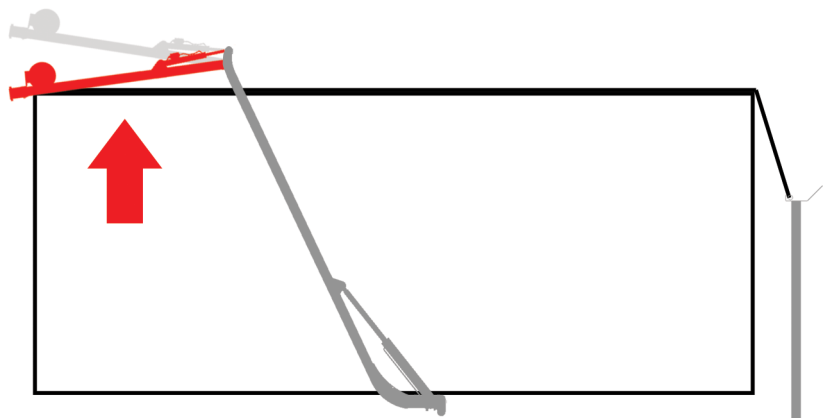
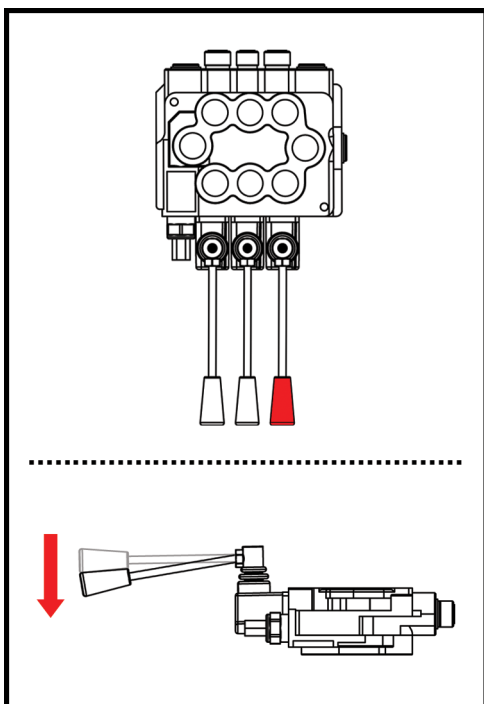
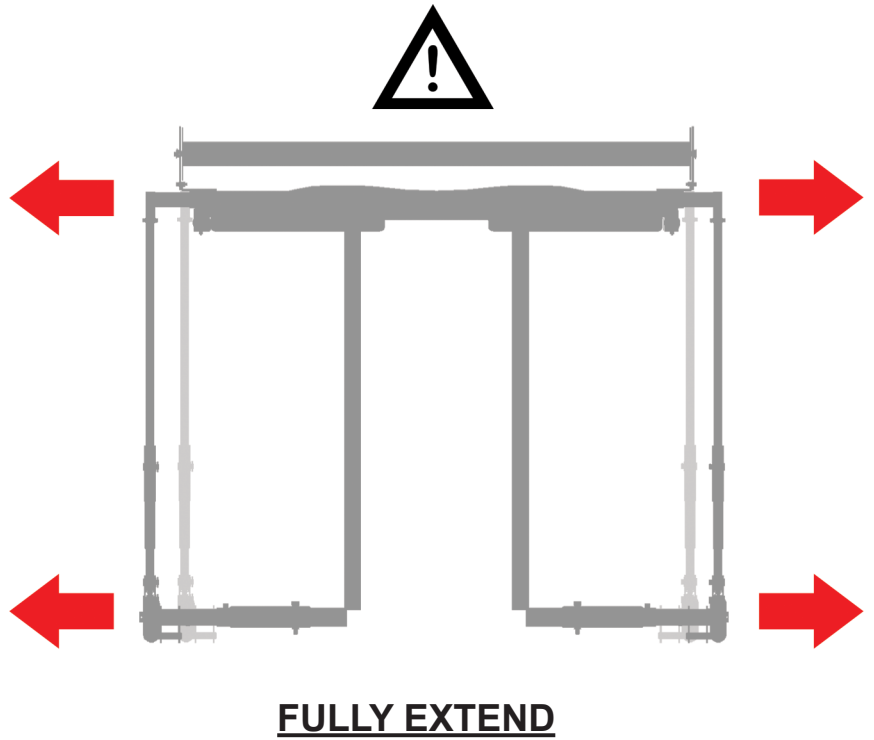
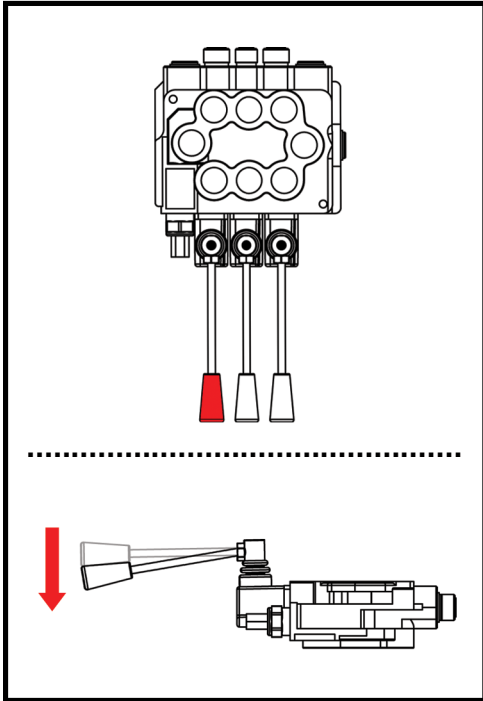

OPERATION - UNCOVERING

FONCTIONNEMENT-DÉCOUVRIR | OPERATION - UNCOVERING

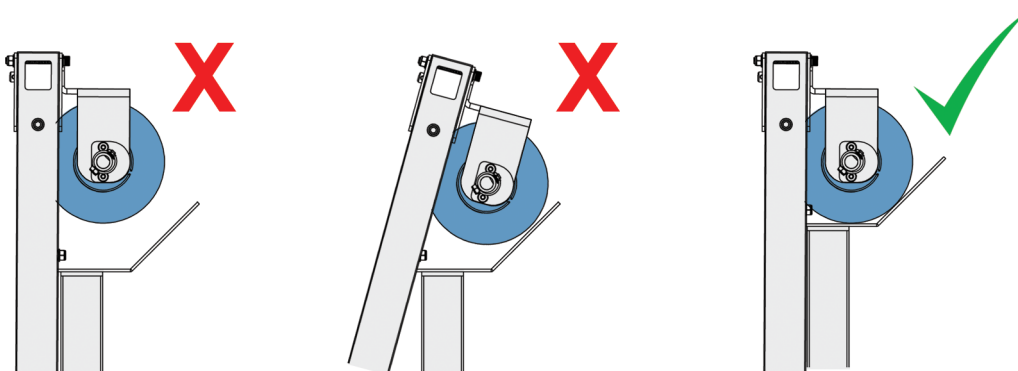
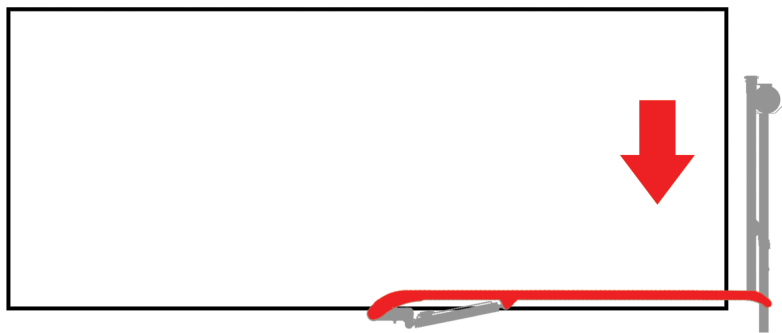
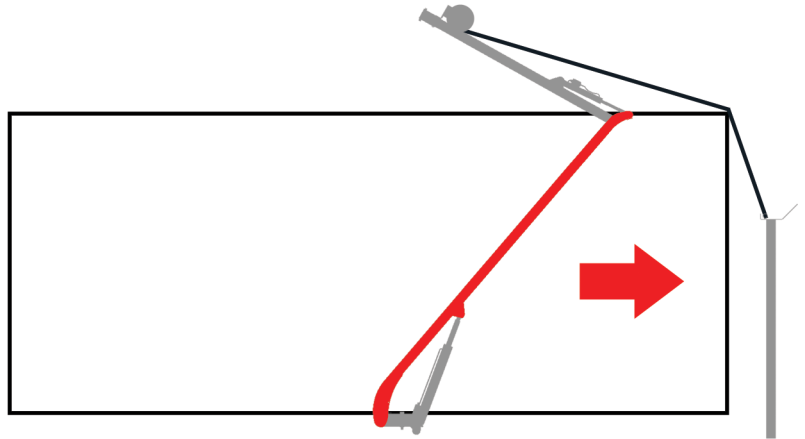
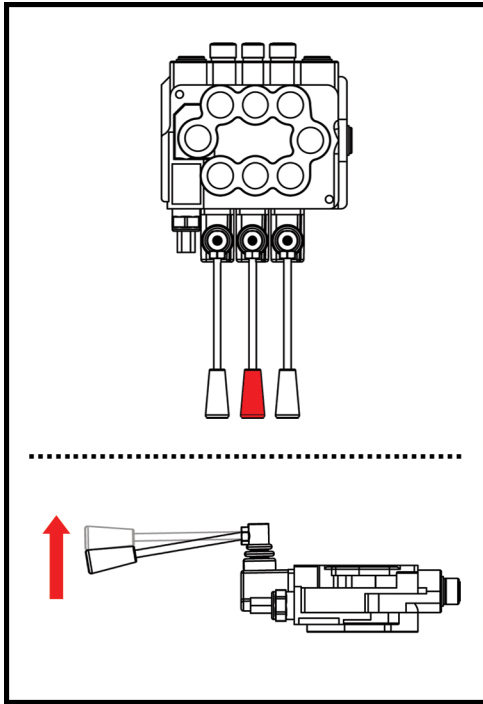

OPERATION - UNCOVERING

FONCTIONNEMENT-DÉCOUVRIR | OPERATION - UNCOVERING

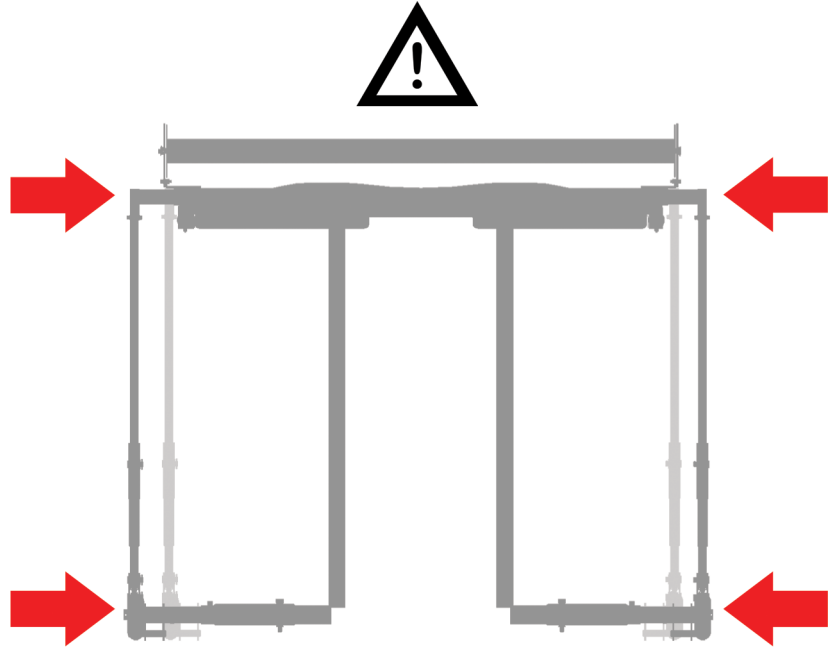
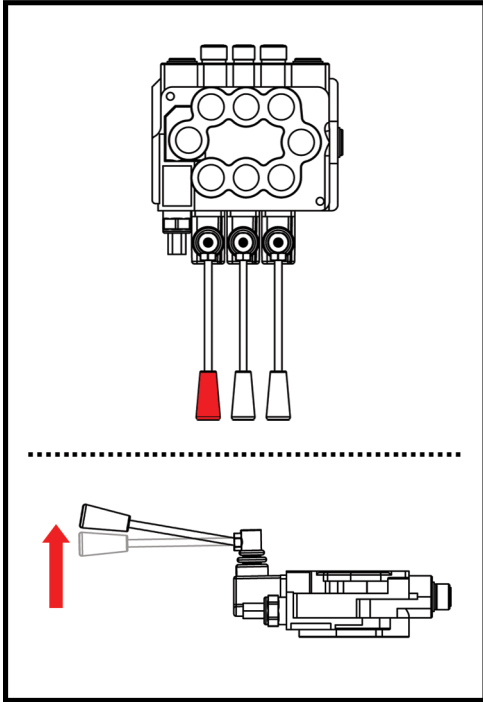

FULLY RETRACT

SYSTEM MAINTENANCE

MAINTENANCE DU SYSTEME | SYSTEMWARTUNG



REGULAR INTERVALS
INTERVALLES RÉGULIERS
INTERVALLIERT REGLER

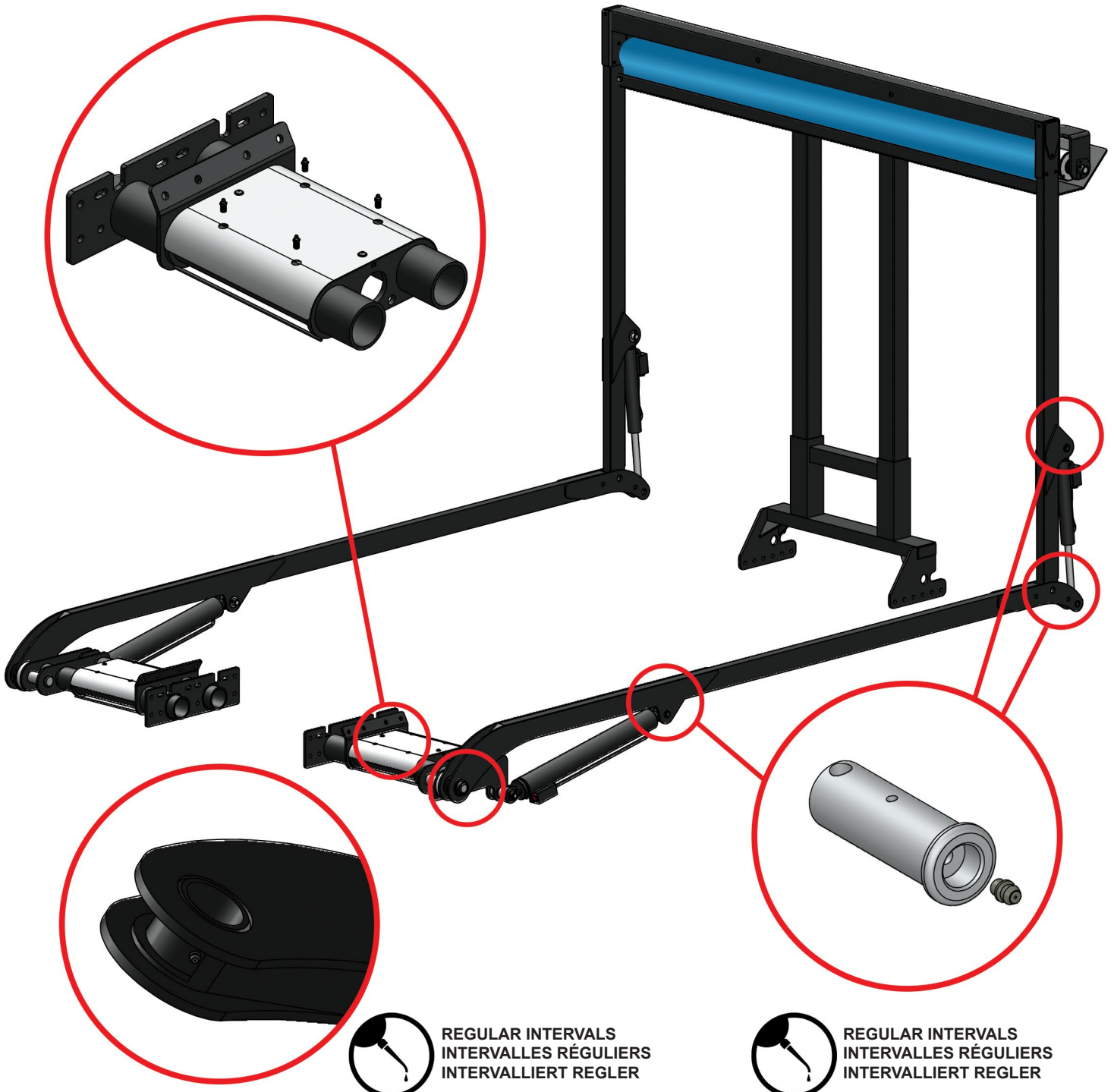

DAILY / MONTHLY CHECKS

SURVEILLANCE QUOTIDIENNE / MENSUELLE | TÄGLICHE / MONATLICHE ÜBERWACHUNG

Daily Visual

(Where Applicable)

- Bungee Rope Condition
- Pneumatic Hoses & Fittings
- Electrical Wiring & Connectors
- Hydraulic Cylinders & Hoses
- Tarpulin Condition
- Structural & Stability Of Mechanism
- Hydraulic Leaks

Monthly Service

(Where Applicable)

- Weld Checks
- Bolts & Fixings
- Rollerbar Tension
- Grease Points Lubricated
- Operating Hydraulic Oil
- Remote Batteries





www.transcover.com

INSTALLING ROLLERBAR

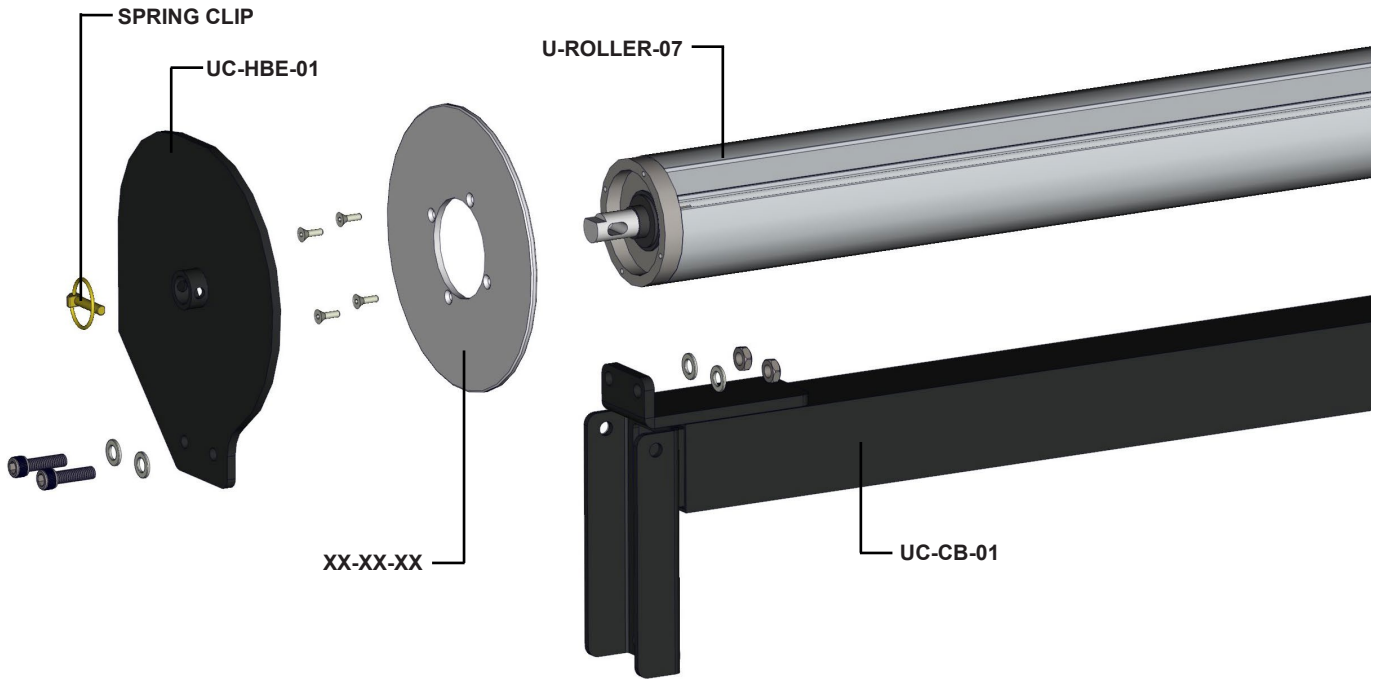
INSTALLATION DE ROLLERBAR | INSTALLATION DER ROLLLEISTE

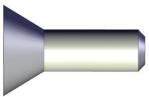

	M12 x 40 SOCKET BOLT	x 4
	M12 NUT	x 4
	M12 WASHER	x 8
	M6 x 15 COUNTERSUNK BOLT	x 8

